

4

3

2

1

- 1.0 GENERAL NOTES
- 1.1 ALL METRIC DIMENSIONS ARE IN BRACKETS [X. X]
- 1.2 FOR PATENT INFO: <https://www.cs-pat.com>

- 2.0 DESIGN NOTES
- 3.0 MANUFACTURING/SPECIAL REQUIREMENTS

3.1 TIGHTEN ALL BOLTS SECURING FLAT PLATES BY THE TURN-OF-NUT METHOD. TIGHTEN ALL U-BOLTS USING TURN-OF-NUT METHOD WITH ATTENTION TO LEAVE EQUAL DISTANCE AND EQUAL FORCE ON EACH LEG OF THE U-BOLT.

- 4.0 TEST
- 5.0 PACKAGING

5.1 PACKAGING SHALL MEET COMMSCOPE REQUIREMENTS PER DOCUMENT IS-PL-3005  
 5.2 PRINTED DOCUMENT TO BE PLACED INSIDE POLYBAG AND THEN IN SHIPPING CONTAINER  
 5.3 EXTRA HARDWARE MAY BE SUPPLIED, BAGGED AND SHIPPED

REVISIONS			
REV.	DESCRIPTION	DATE	APPROVED
A	INITIAL RELEASE	YX1027 05JUN24	XK1001 40197314CMO

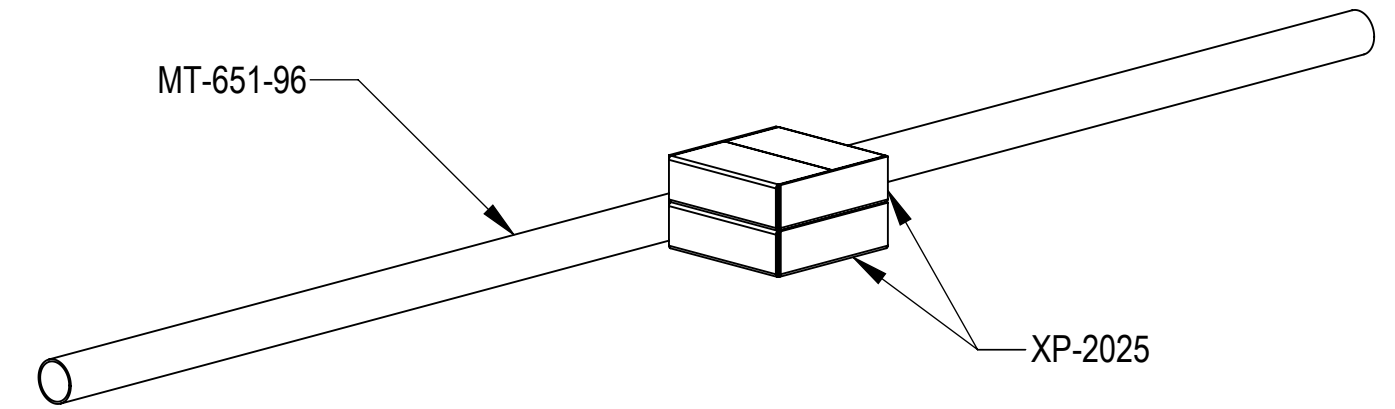
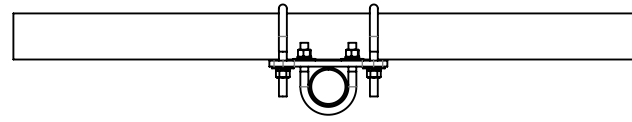

PACKAGING VIEW

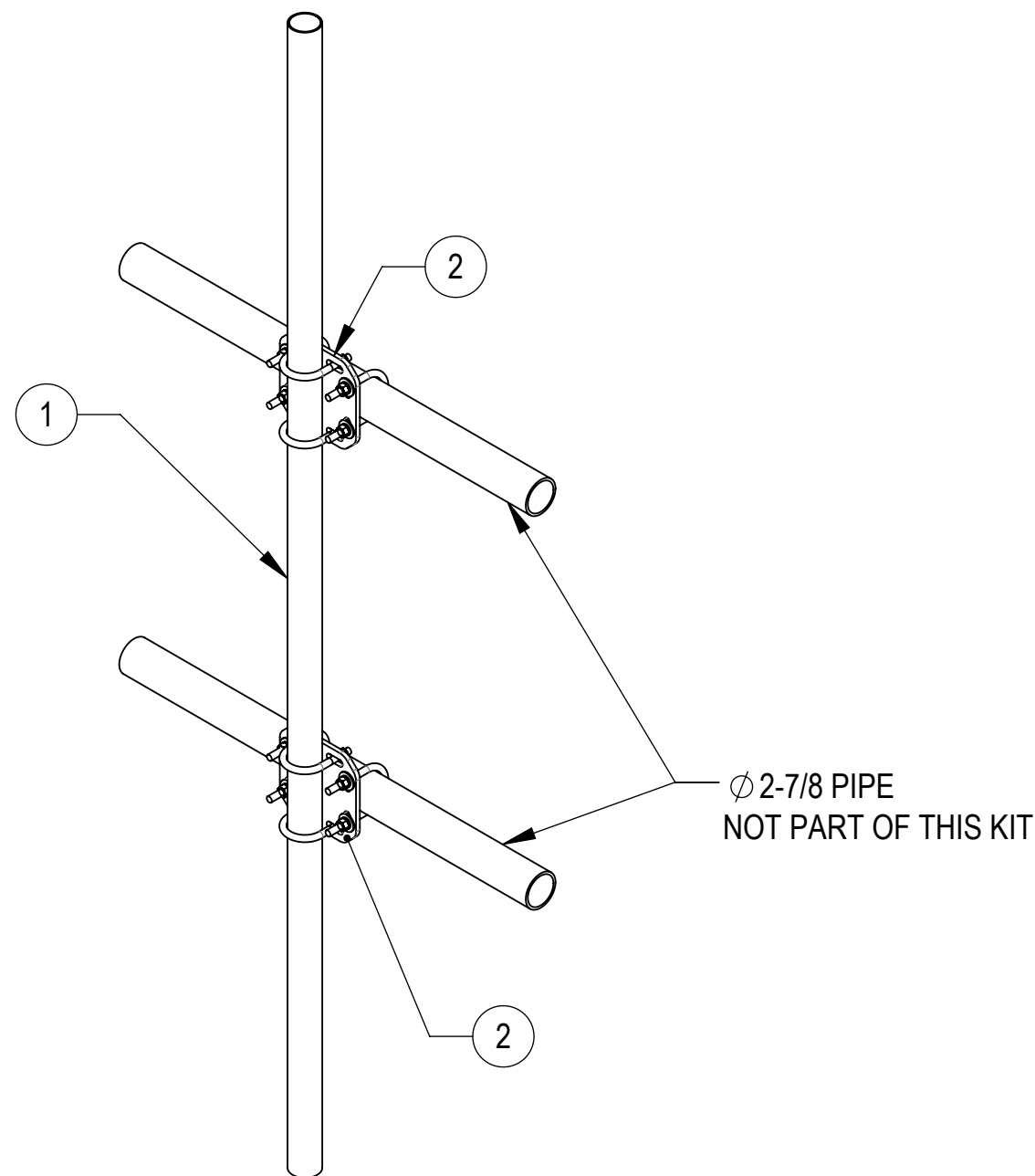
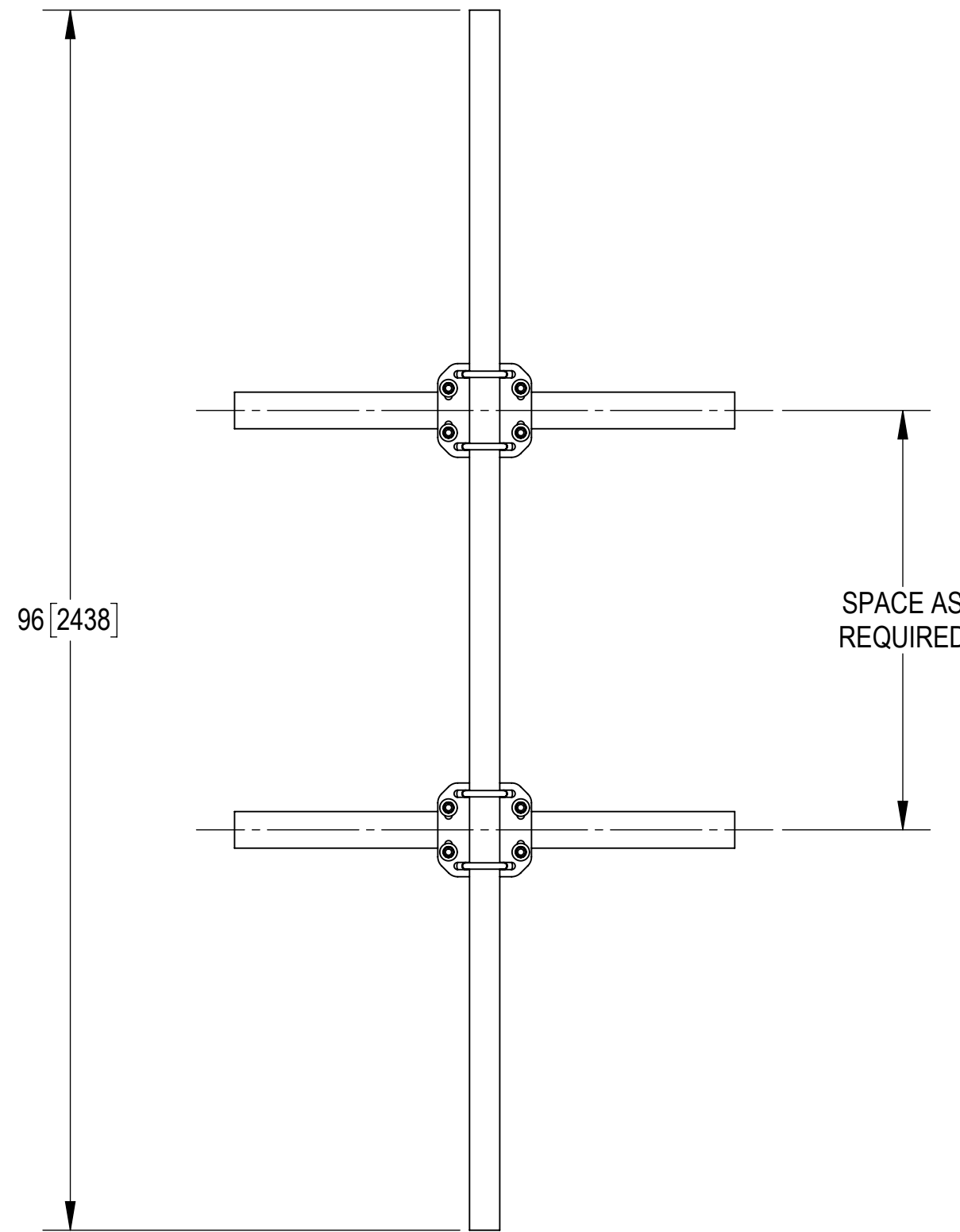

<b>COMMSCOPE, INC. OF NORTH CAROLINA</b>											
TOLERANCES					SAP MATERIAL MASTER						
1 PLACE .X[X] ± 0.2[6.3]		3 PLACE .XXX[X] ± 0.060[1.5]			<b>SF-PK-278-238</b>						
2 PLACE .XX[X] ± 0.12[3.0]		ANGLES ± 2°									
FINISH					MATERIAL						
UNLESS OTHERWISE SPECIFIED DIMENSIONS ARE IN INCHES INTERPRET PER ANSI Y 14.5M-1994	NAME		DATE		<b>PIPE MNT, 2-7/8" CO, 2-3/8" X 96" PIPE</b>						
	CE YX1027		05JUN24								
	RW YX1027		06/07/2024		SCALE <b>1:10</b>		DOCUMENT NO. <b>SF-PK-278-238</b>				
	AD XK1001		06/07/2024								
	RE YMENG		06/12/2024								
ECN 40197314CMO											
SIZE		Auth Group		INSL		MODEL			DRAWING		
<b>C</b>						VERSION		STATUS		REVISION	
						00		RE		A	
HEIGHT 96"		MASS 77.09		DENSITY lbs/in³		VERSION 00		STATUS RE		REVISION A	
LENGTH 7.38"		VOLUME 271.49		lbs		REVISION 00		STATUS RE		REVISION A	
WIDTH 6.90"		SURFACE AREA 3177.36		in³		REVISION 00		STATUS RE		REVISION A	
										SHEET 1 OF 1	