

4

3

2

1

- 1.0 GENERAL NOTES
- 1.1 ALL DIMENSIONS ARE IN MM, IMPERIAL DIMENSIONS ARE IN INCHES AND SHOWN IN BRACKETS [X.X]
- 2.0 DESIGN NOTES
- 3.0 MANUFACTURING/SPECIAL REQUIREMENTS
- 3.1 TIGHTEN HARDWARES, TORQUE VALUE ARE SHOWN BELOW AS REFERENCE,
  - M5: TORQUE 23.0 IN-LB OR 2.6 N-M
  - M6: TORQUE 40.0 IN-LB OR 4.5 N-M (W/ CLIP NUT)
  - M6: TORQUE 46.0 IN-LB OR 5.2 N-M (W/ THREADED CAST AL)
  - M6: TORQUE 75.0 IN-LB OR 8.5 N-M (W/ STEEL NUT)
  - M8: TORQUE 6.6 FT-LB OR 9.0 N-M (W/ THREADED CAST AL)
- 3.2 CONFIGURATIONS AND QUANTITY OF EQUIPMENTS IN INSTALLATION ARE LISTED ON TABLE.
- 3.3 EQUIPMENT INSTALLATION INSTRUCTION ON PAGE 2.

REVISIONS			
REV.	DESCRIPTION	DATE	APPROVED
A	INITIAL RELEASE	YC1059 26JUL23	ZM1026 40175933CMO

CONFIGURATION	3.2 APPROVED NOKIA RADIO CONFIGURATIONS				
	AZHL	APAM	AHFIB	1830 "POD-8"	CBC1726T-4310
1	1	1	1	1	2

<b>COMMSCOPE, INC. OF NORTH CAROLINA</b>										
TOLERANCES					SAP MATERIAL MASTER					
1 PLACE .X[X] ±		3 PLACE .XXX[X] ±			860661736-MV2-C07-INSTALL					
2 PLACE .XX[X] ±		ANGLES ±								
FINISH					MATERIAL					
UNLESS OTHERWISE SPECIFIED DIMENSIONS ARE IN INCHES INTERPRET PER ANSI Y 14.5M-1994	CE	YC1059	26JUL23	860661736-MV2-C07-INSTALL						
	RW	YC1059	08/04/2023							
	AD	ZM1026	08/04/2023	SCALE		DOCUMENT NO.				
	RE	DM1121	08/04/2023	<b>2:1</b>		<b>860661736-MV2-C07-INSTALL</b>				
	ECN 40175933CMO									
DENSITY	lbs/in³									
MASS	lbs									
VOLUME	in³									
SURFACE AREA	in²									
HEIGHT		SIZE	Auth Group	INSL	MODEL			DRAWING		
LENGTH		<b>C</b>			VERSION	STATUS	REVISION	VERSION	STATUS	REVISION
WIDTH					RE	A	00	RE	A	
SHEET 1 OF 7										

4

3

2

1

4

3

2

1

D

D

C

C

B

B

A

A

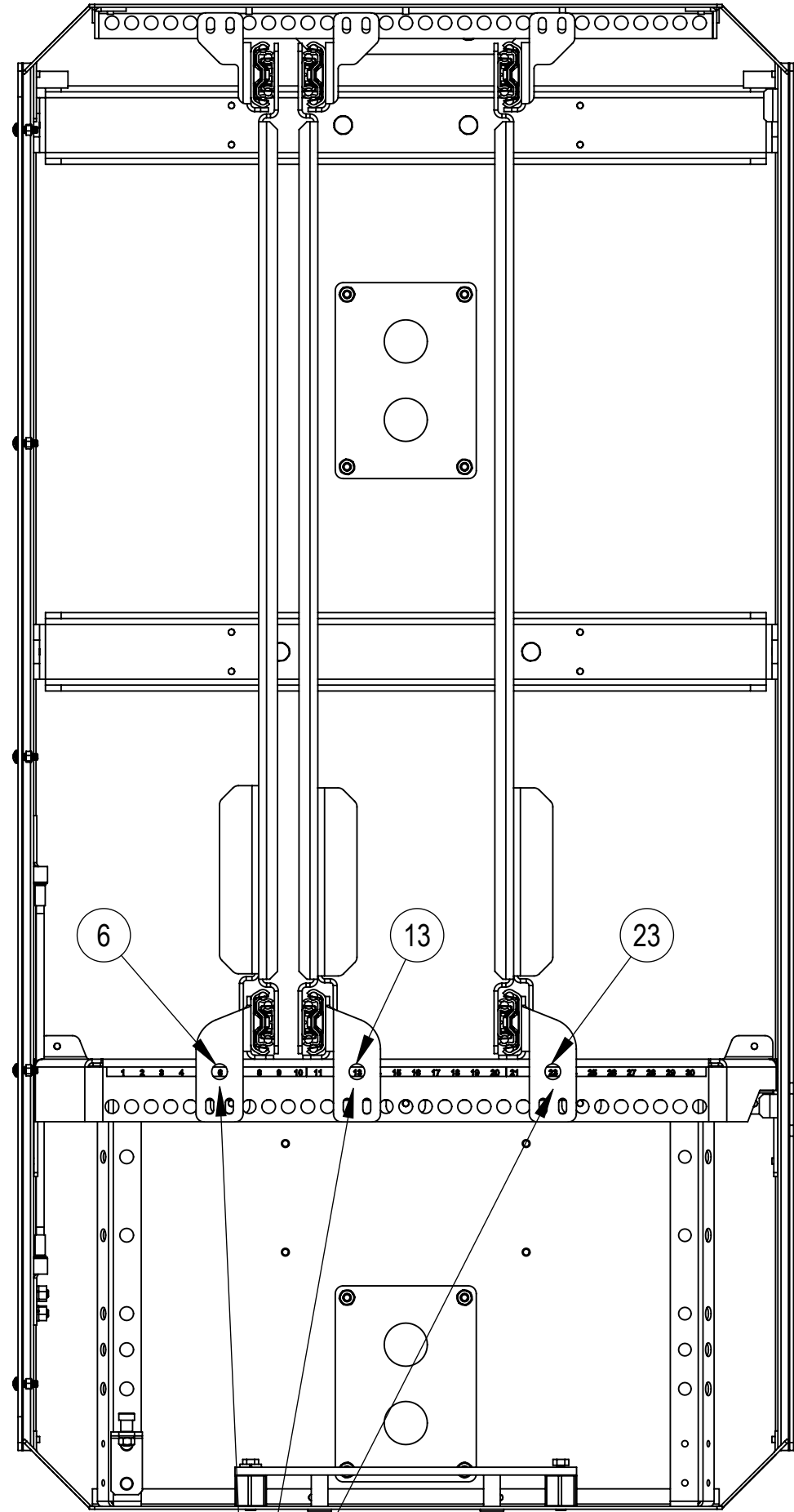

LEFT EQUIPMENT  
CENTER OR REAR

RIGHT EQUIPMENT  
CENTER OR REAR

CENTER EQUIPMENT  
FRONT, AND/OR REAR

BASE ENCLOSURE ARE SHIPPED WITH 3 SLIDE PANELS  
CONFIGURE SLIDE PANELS PER EQUIPMENT CONFIGURATION

EMPTY ENCLOSURE CONFIGURATION

COMMSCOPE, INC. OF NORTH CAROLINA

TITLE  
860661736-MV2-C07-INSTALL

SIZE <b>C</b>	SCALE <b>2:1</b>	DOCUMENT NO. 860661736-MV2-C07-INSTALL
------------------	---------------------	---

DRAWING			SHEET 2 OF 7
VERSION	STATUS	REVISION	
00	RE	A	

© 2023 CommScope, Inc. Confidential

4

3

2

1

# NOKIA EQUIPMENT MOUNTING INSTALLATION

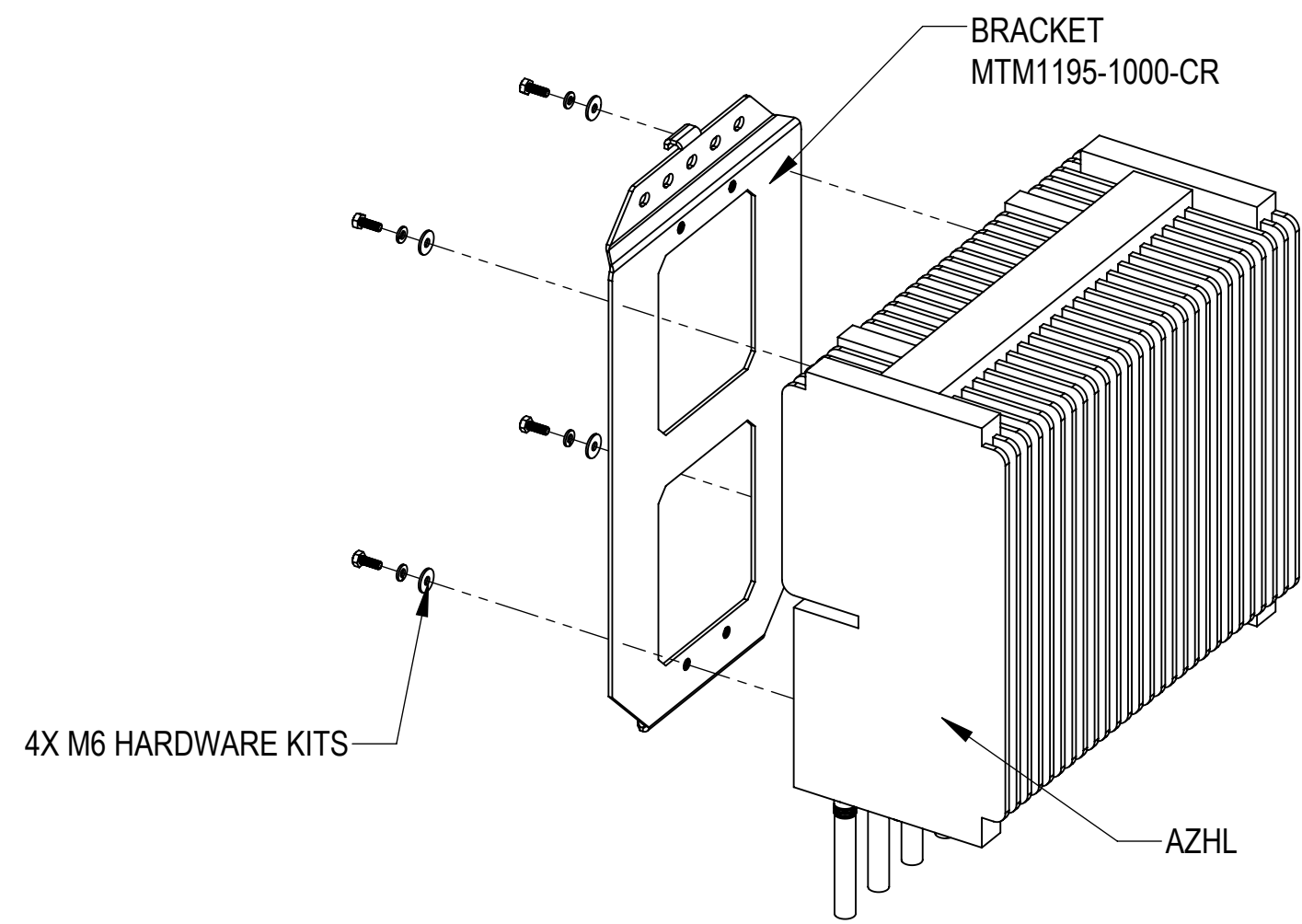

**AZHL:**  
INSTALL AZHL TO THE MOUNTING BRACKET MTM1195-1000-CR USING 4 SETS OF M6 HEX BOLTS, LOCK WASHERS AND FLAT WASHERS, ACCORDING TO THE ACTUAL SITUATION ON-SITE DRILLING INSTALLATION

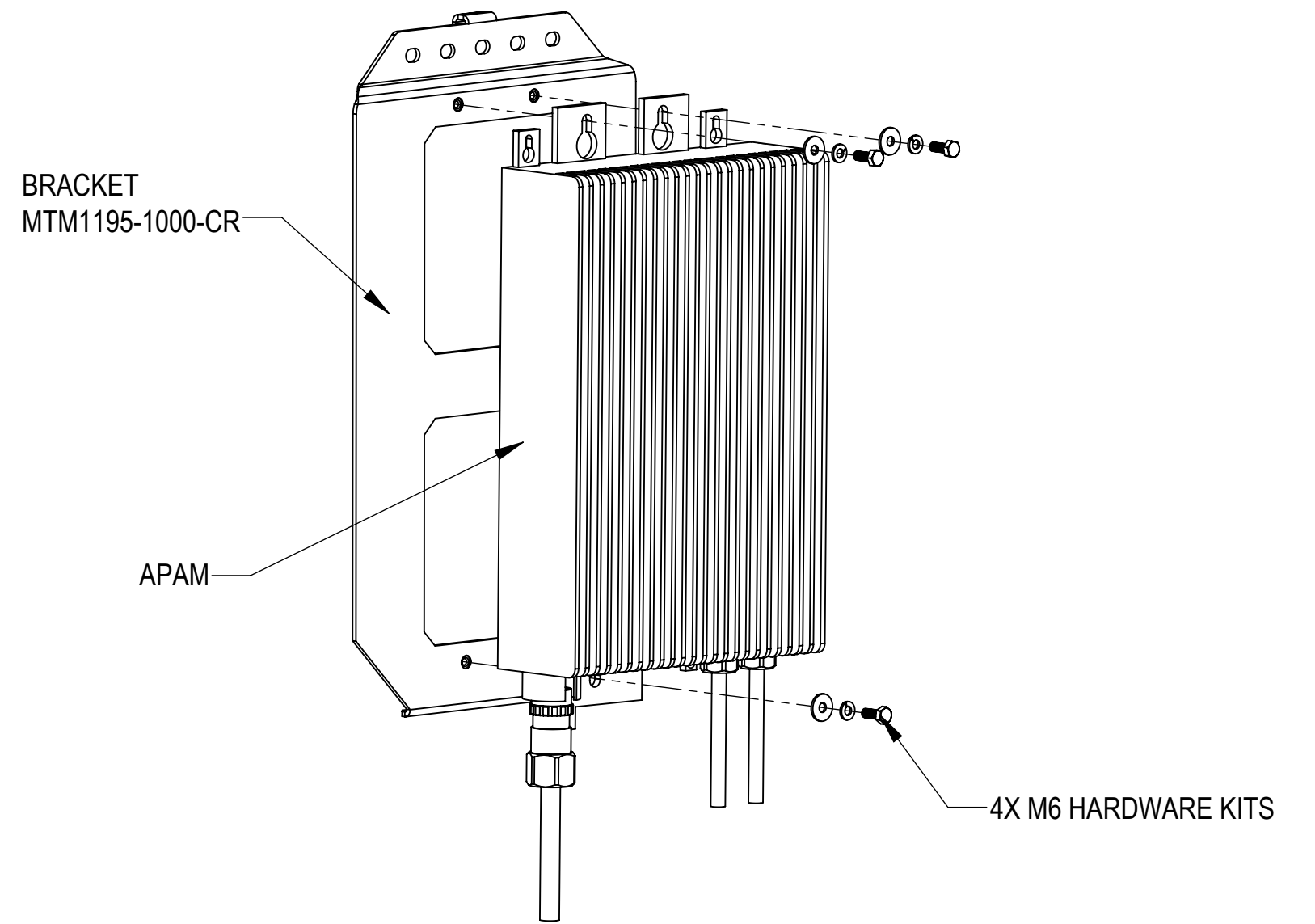

**APAM**  
INSTALL APAM TO THE MOUNTING BRACKET MTM1195-1000-CR USING 4 SETS OF M6 HEX BOLTS, LOCK WASHERS AND FLAT WASHERS AS SHOWN

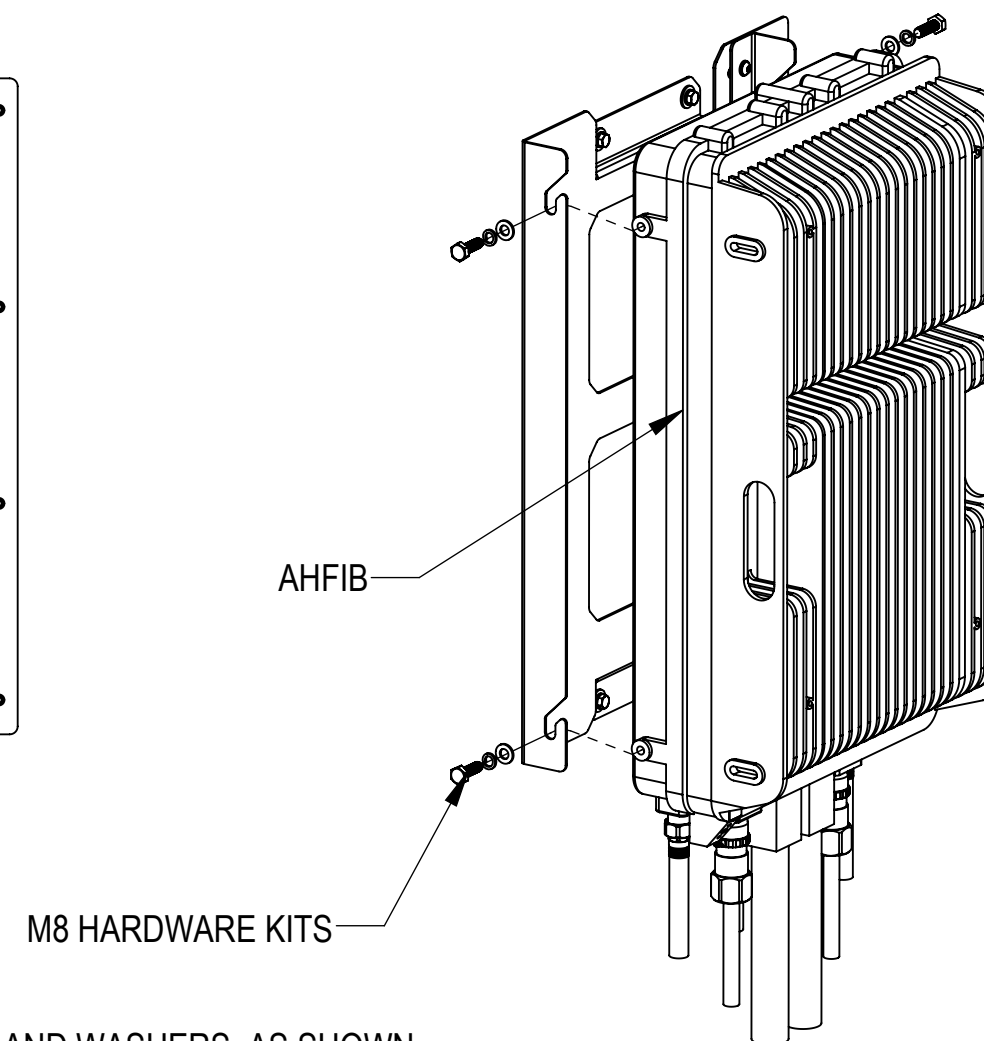
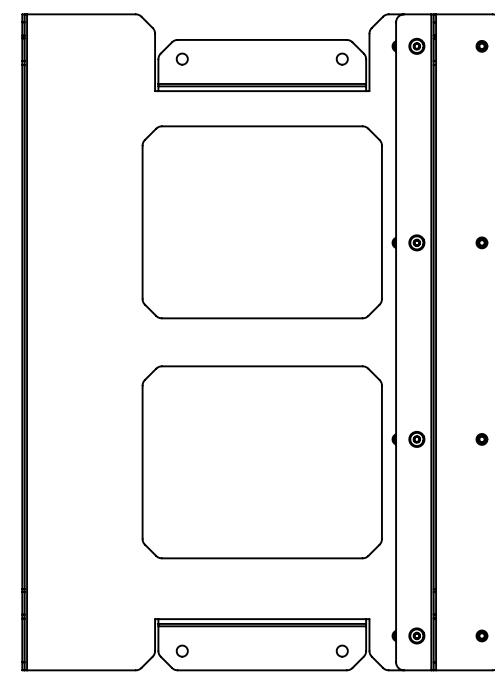
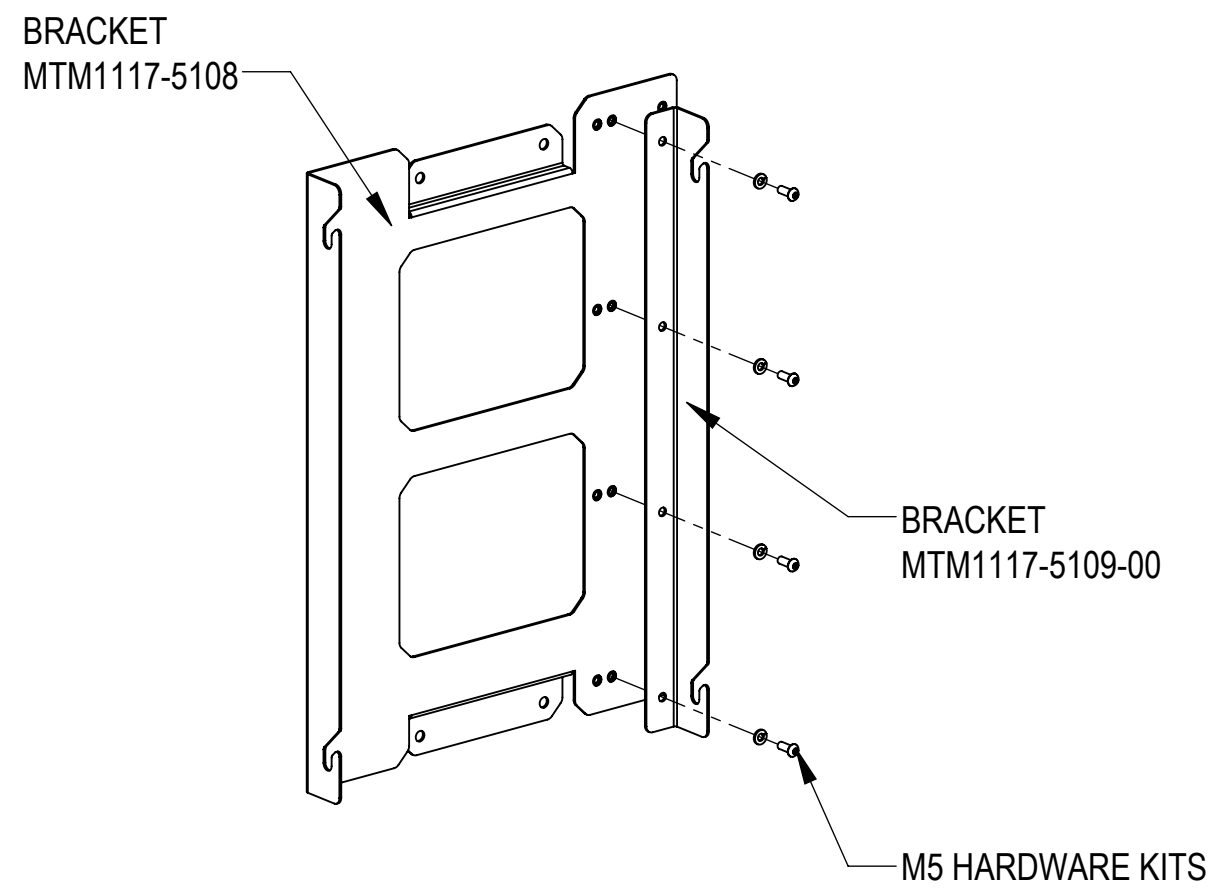

- AHFIB**  
A) INSTALL MTM1117-5109-00 TO THE MOUNTING BRACKET MTM1117-5108 USING 4 SETS OF M5 HEX BOLTS AND WASHERS AS SHOWN  
B) INSTALL AHFIB TO THE MOUNTING BRACKET MTM1117-5108 AND MTM1117-5109-00 USING 4 SETS OF M6 HEX BOLTS, LOCK WASHERS AND FLAT WASHERS  
C) THE EXISTING BRACKET MTM1117-5108 AND MTM1117-5109-00 ARE IN THE MTM117-8001 KITS PACKAGE

COMMSCOPE, INC. OF NORTH CAROLINA				
TITLE 860661736-MV2-C07-INSTALL				
SIZE C	SCALE 2:1	DOCUMENT NO. 860661736-MV2-C07-INSTALL		
		DRAWING		SHEET 3 OF 7
		VERSION 00	STATUS RE	

# NOKIA EQUIPMENT MOUNTING INSTALLATION

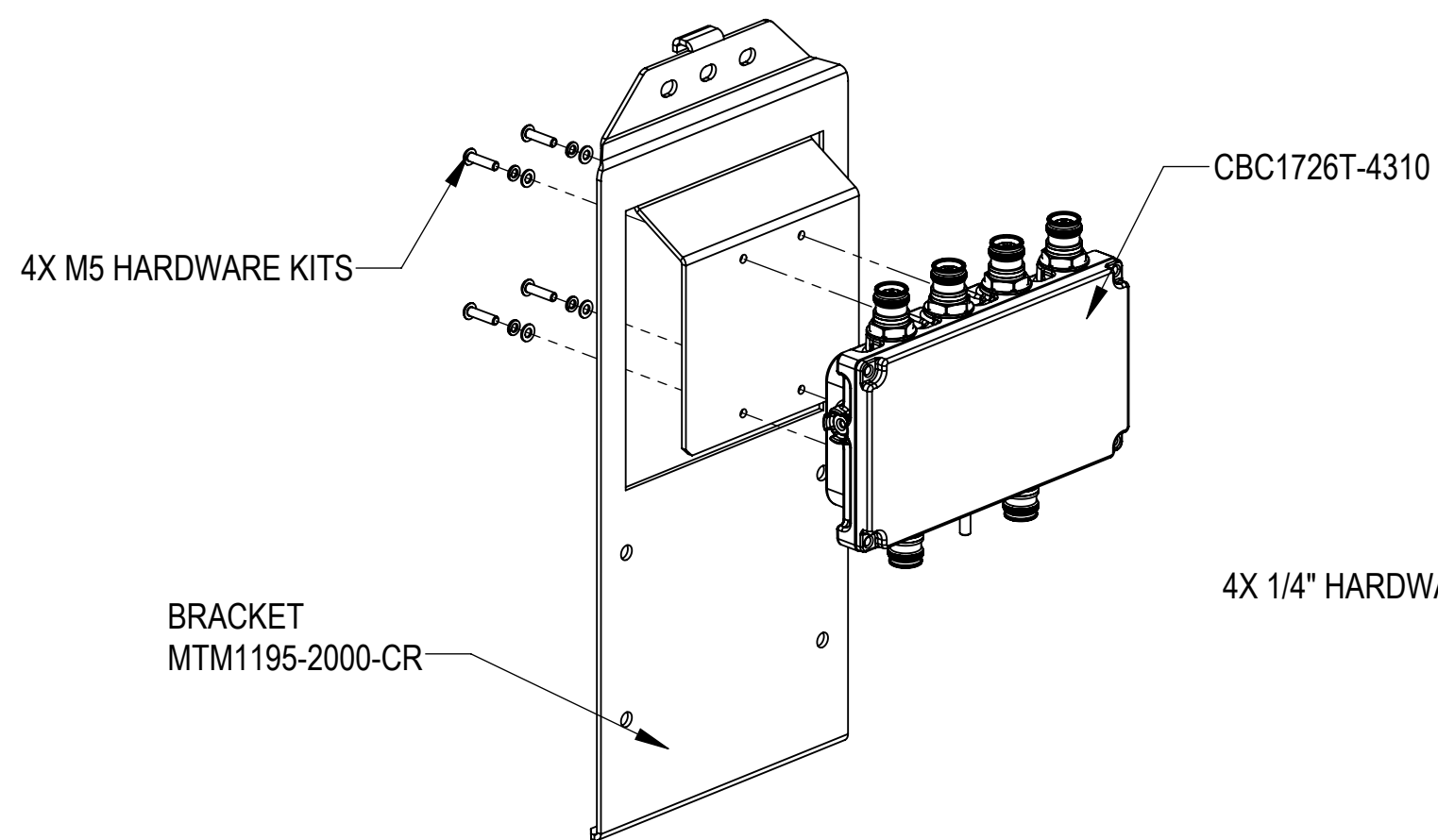

**CBC1726T-4310**  
 INSTALL CBC1726T-4310 TO THE MOUNTING BRACKET MTM1195-2000-CR USING 4 SETS OF M5 HEX BOLTS, LOCK WASHERS AND FLAT WASHERS AS SHOWN

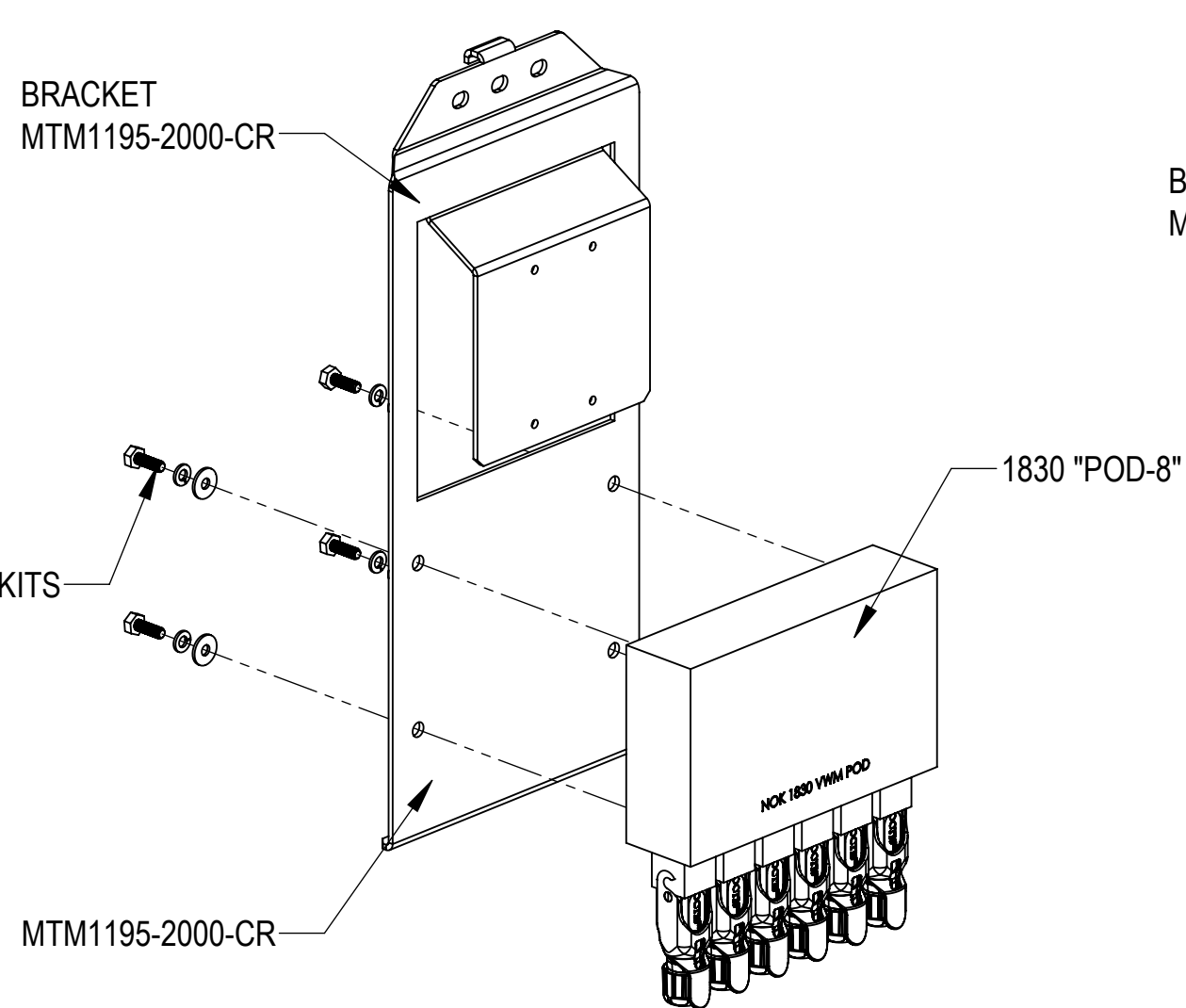

**1830 "POD-8"**  
 INSTALL 1830 "POD-8" TO THE MOUNTING BRACKET MTM1195-2000-CR USING 4 SETS OF 1/4" HEX BOLTS, LOCK WASHERS AND FLAT WASHERS AS SHOWN

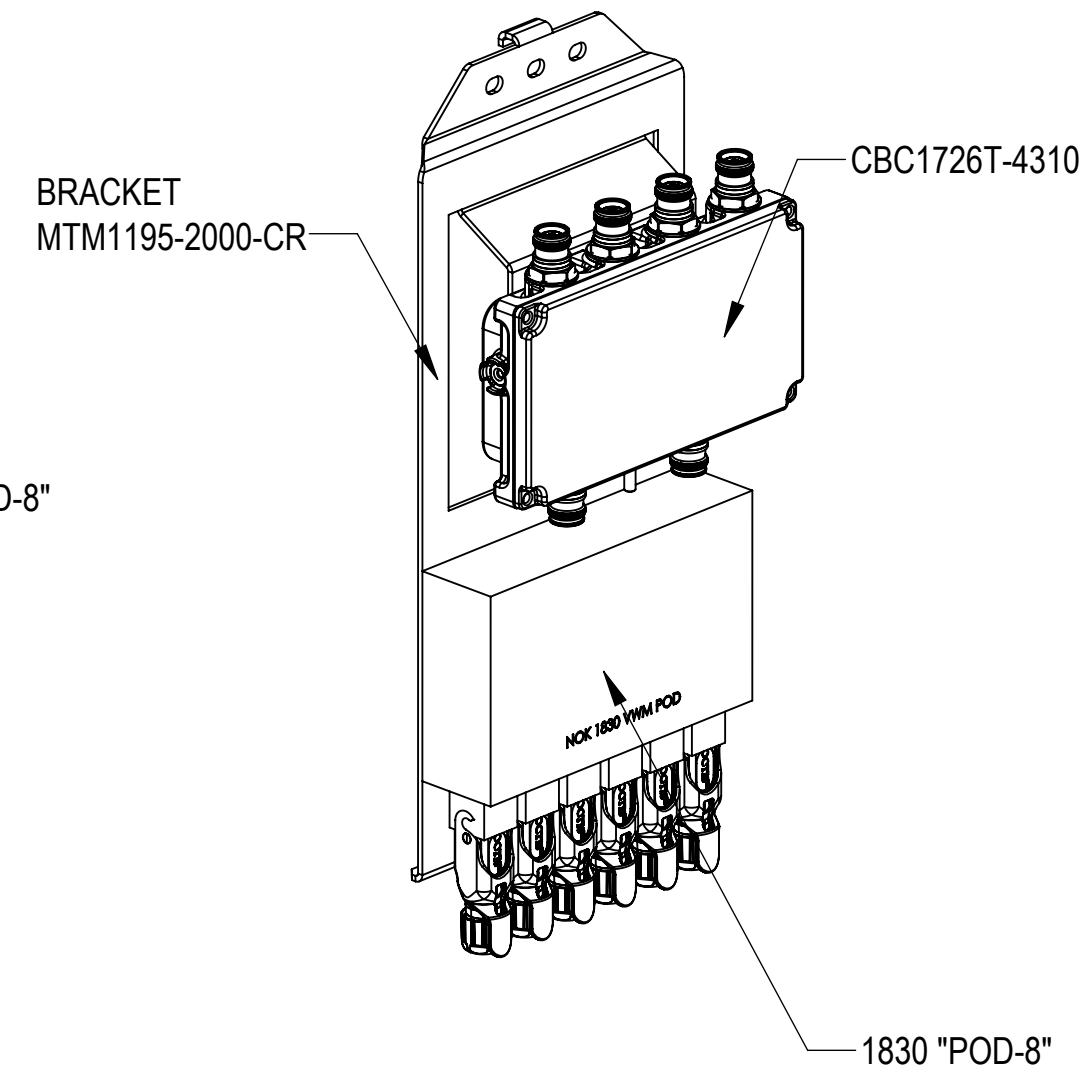

INSTALL CBC1726T-4310 AND NOK 1830 "POD-8" TOGETHER ON THE MOUNTING BRACKET MTM1195-2000-CR

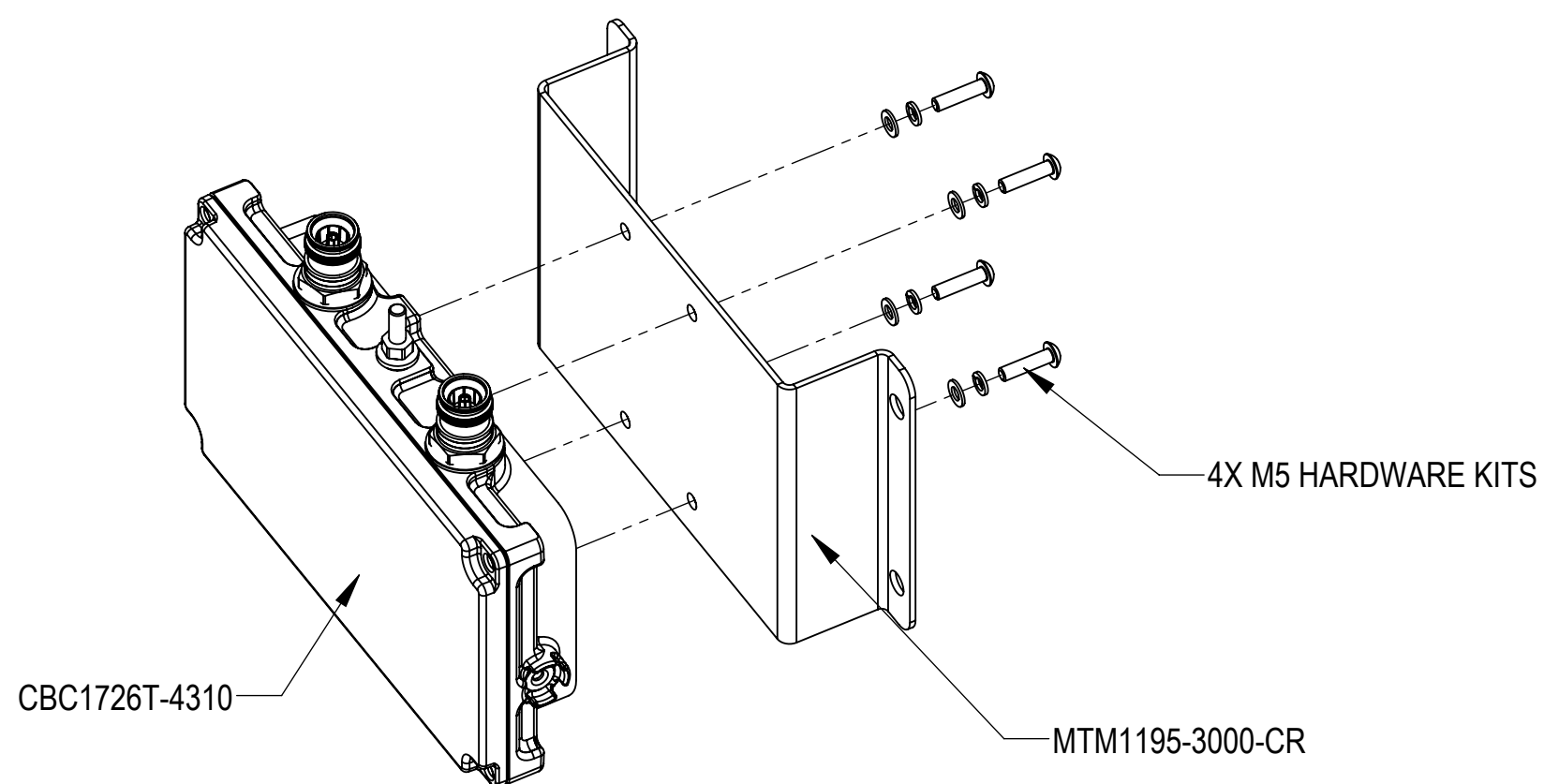

**CBC1726T-4310**  
 INSTALL CBC1726T-4310 TO THE MOUNTING BRACKET MTM1195-3000-CR USING 4 SETS OF M5 HEX BOLTS, LOCK WASHERS AND FLAT WASHERS AS SHOWN

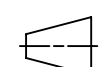
COMMScope, INC. OF NORTH CAROLINA					
TITLE 860661736-MV2-C07-INSTALL					
SIZE <b>C</b>	SCALE <b>2:1</b>	DOCUMENT NO. 860661736-MV2-C07-INSTALL			
 		DRAWING			SHEET 4 OF 7
		VERSION 00	STATUS RE	REVISION A	

4

3

2

1

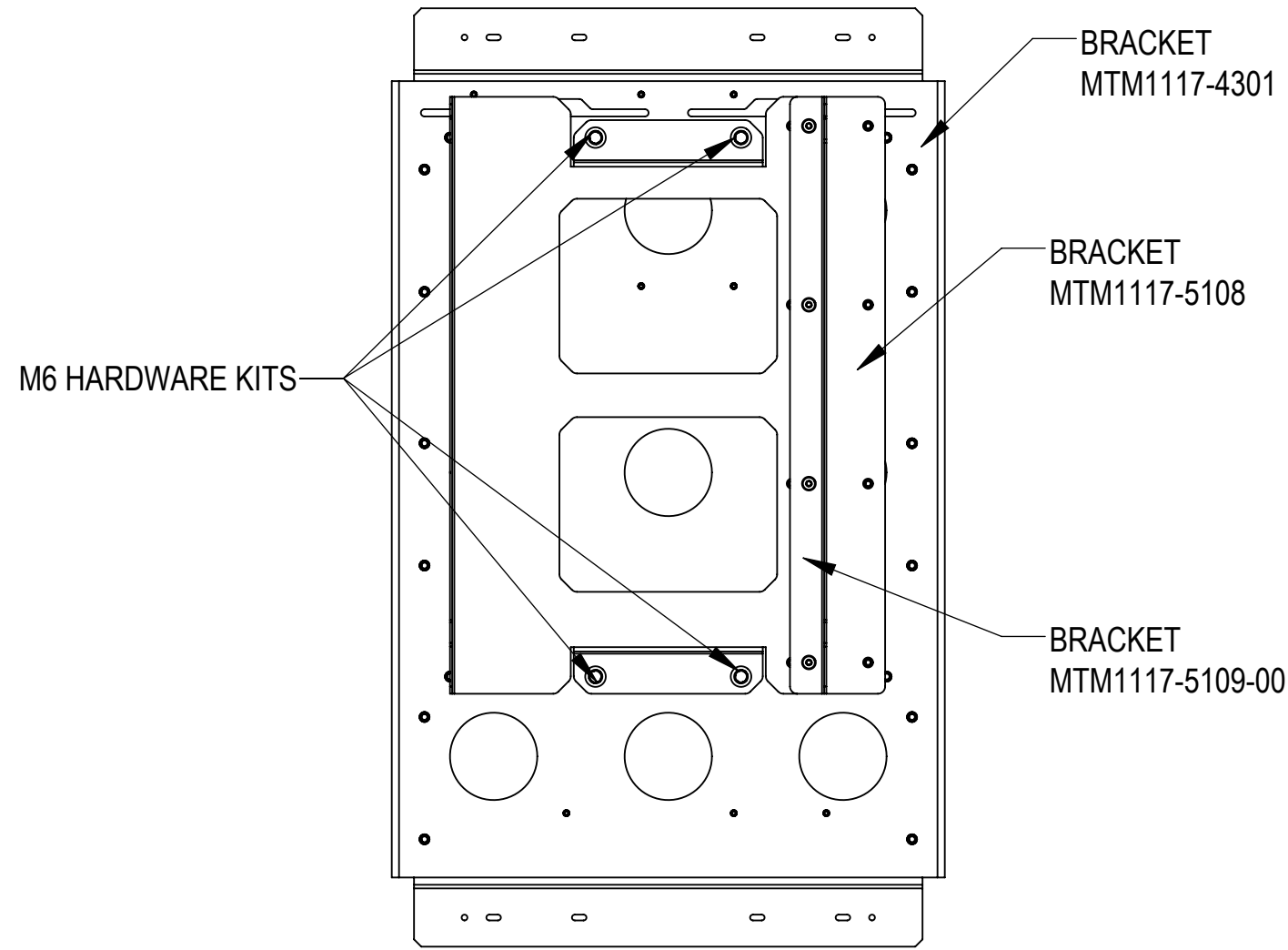

AHFIB BRACKET INSTALL LOCATION

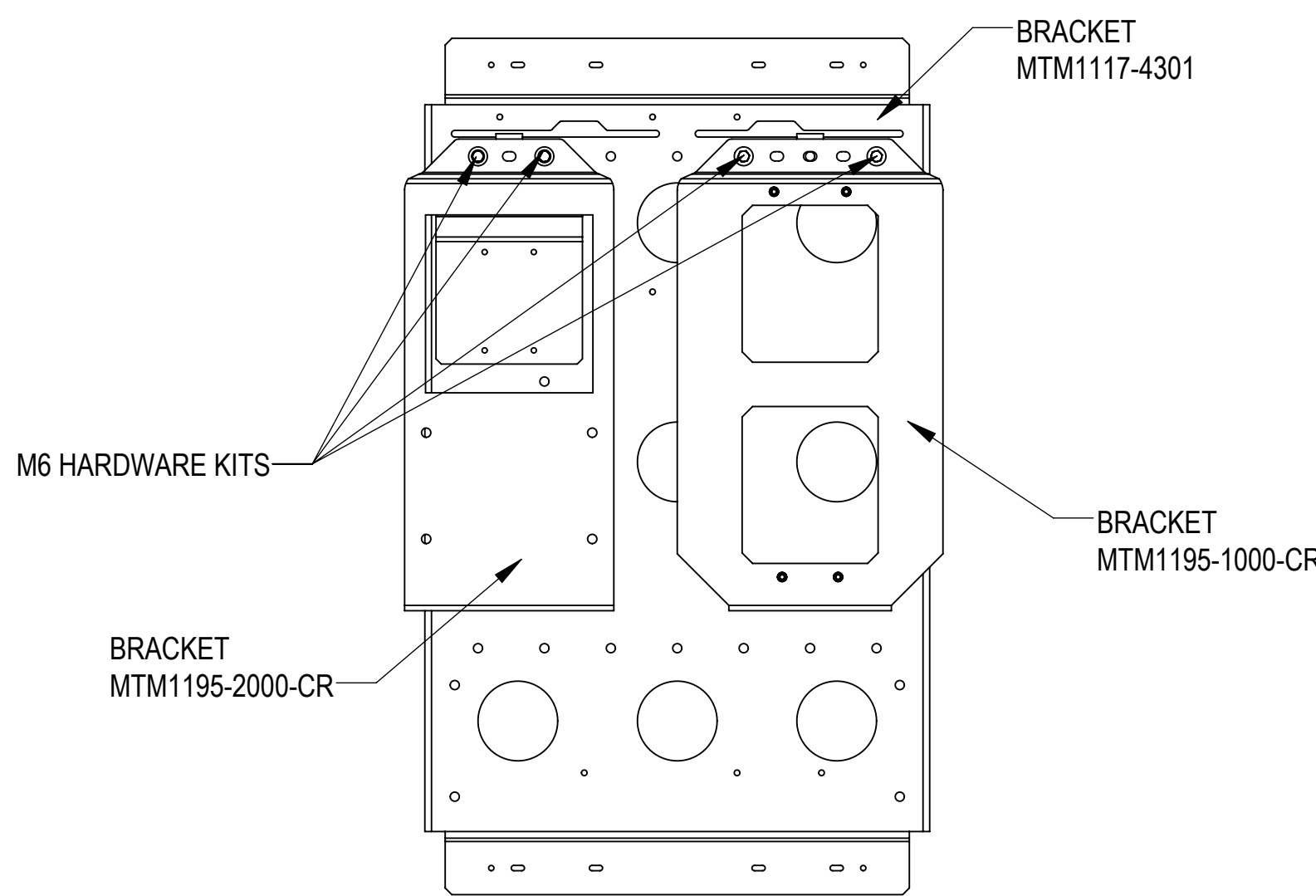

CBC1726T-4310 & POD-8 & APAM BRACKET INSTALL LOCATION

**SLIDING BLADE ASSEMBLY  
(LEFT FACING VIEW)**

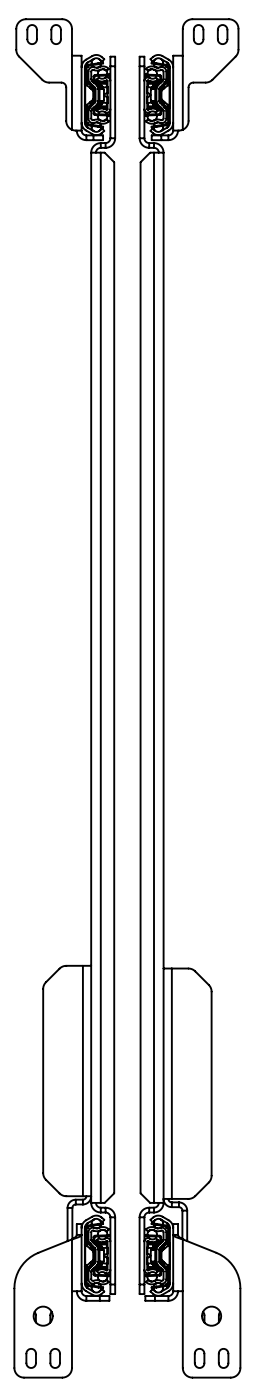

**SLIDING BLADE ASSEMBLY  
(FRONT VIEW)**

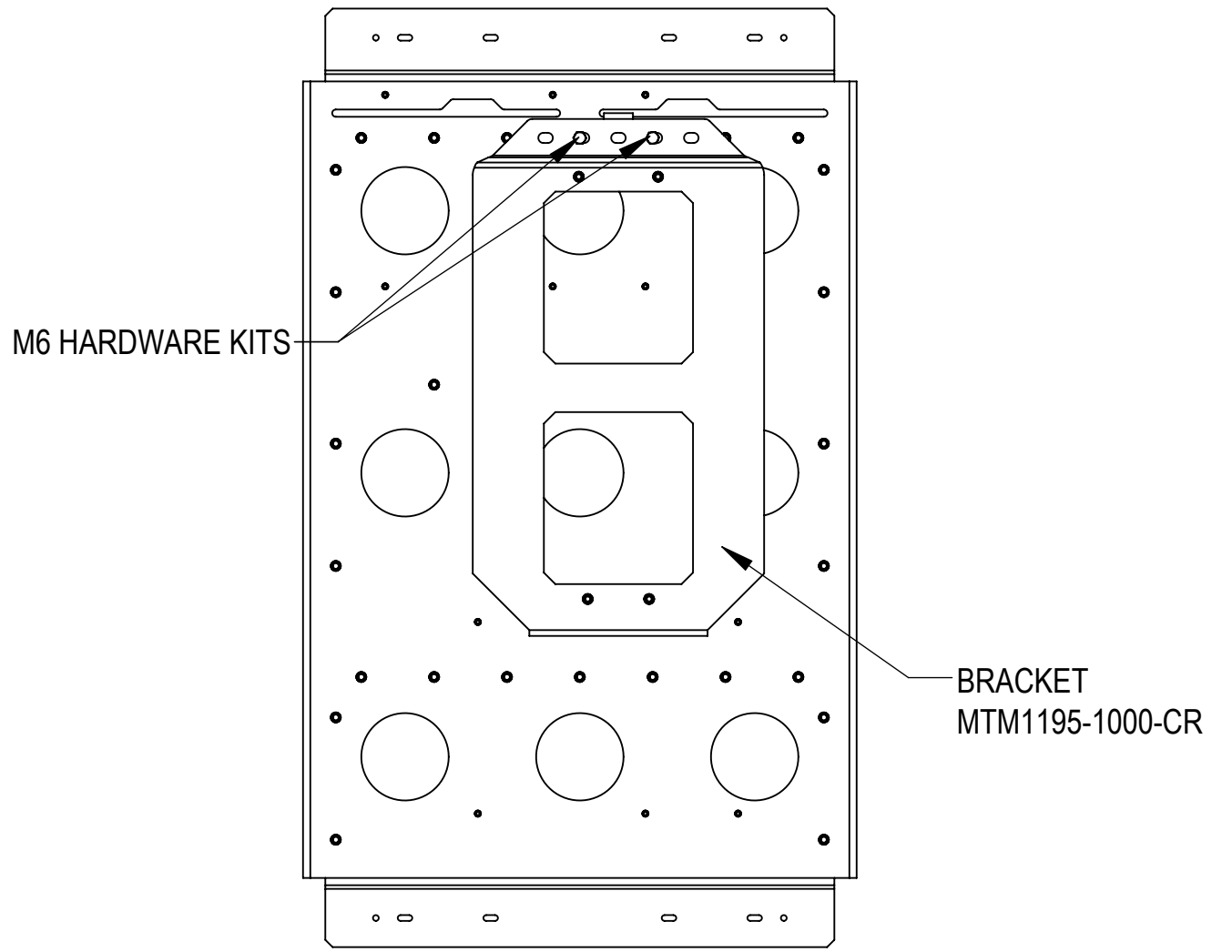

AZHL BRACKET INSTALL LOCATION

**SLIDING BLADE ASSEMBLY  
(RIGHT FACING VIEW)**

COMMSCOPE, INC. OF NORTH CAROLINA				
TITLE 860661736-MV2-C07-INSTALL				
SIZE <b>C</b>	SCALE <b>2:1</b>	DOCUMENT NO. 860661736-MV2-C07-INSTALL		
		DRAWING		SHEET 5 OF 7
		VERSION 00	STATUS RE	

4

3

2

1

D

D

C

C

B

B

A

A

4

3

2

1

D

D

C

C

B

B

A

A

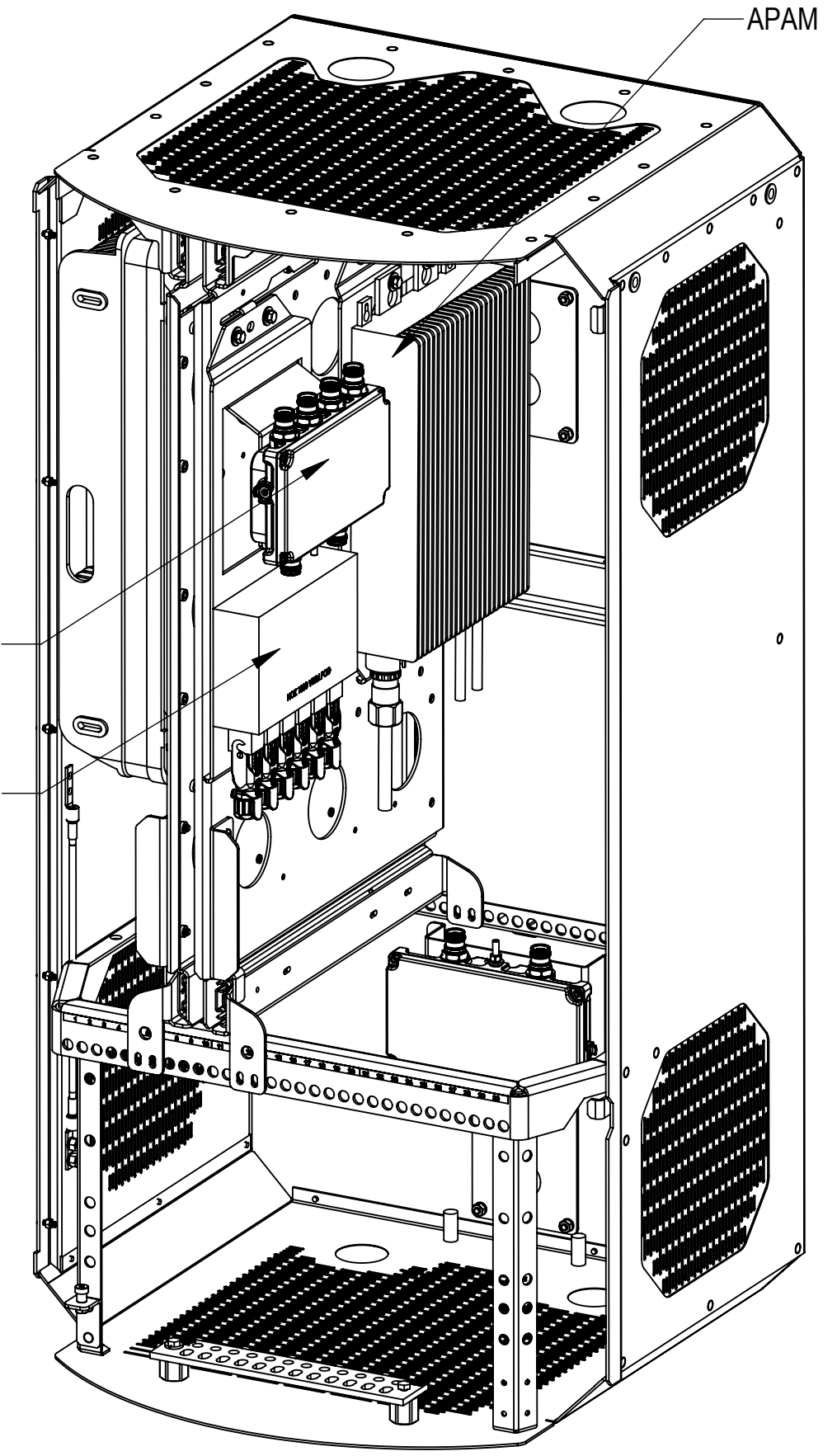
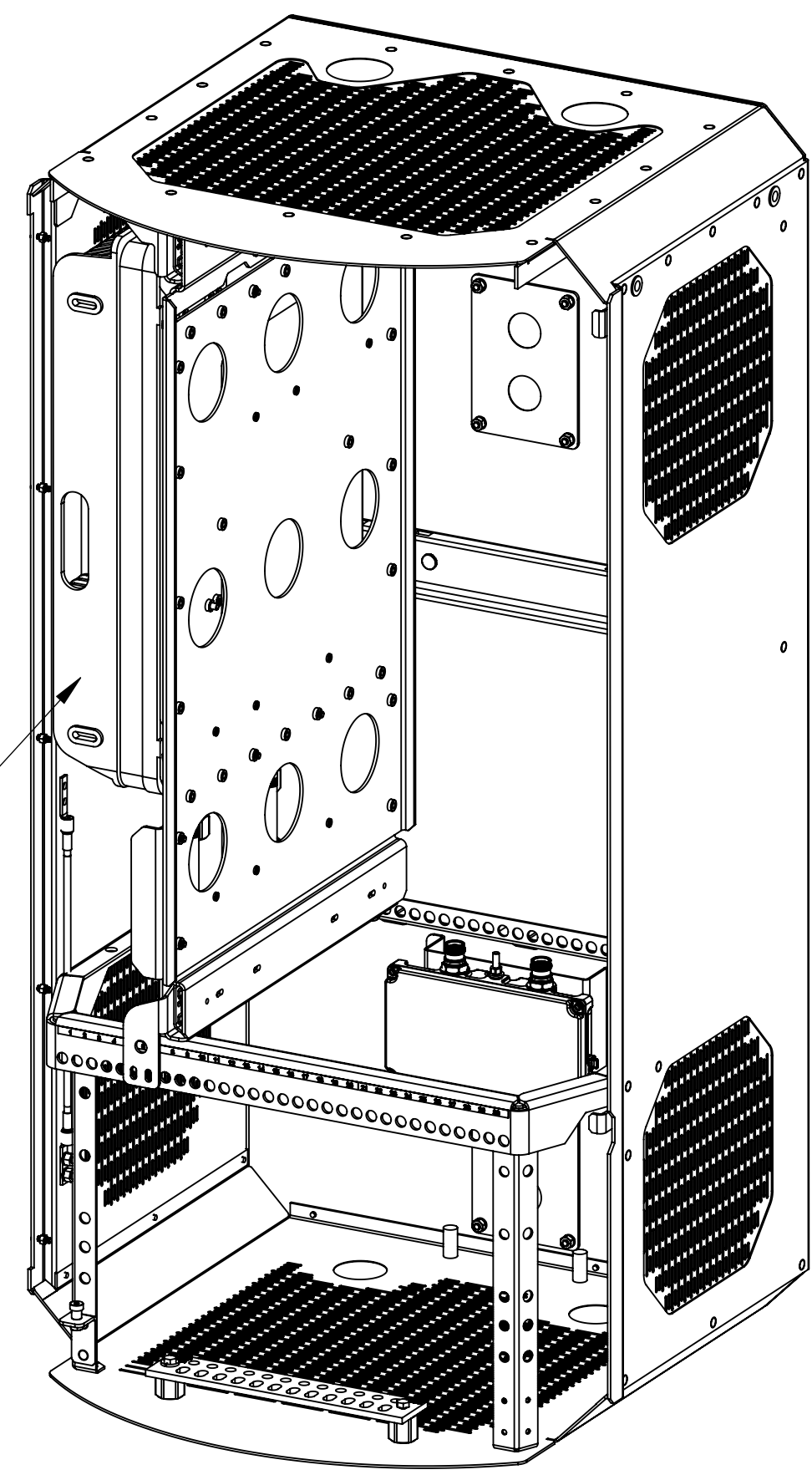
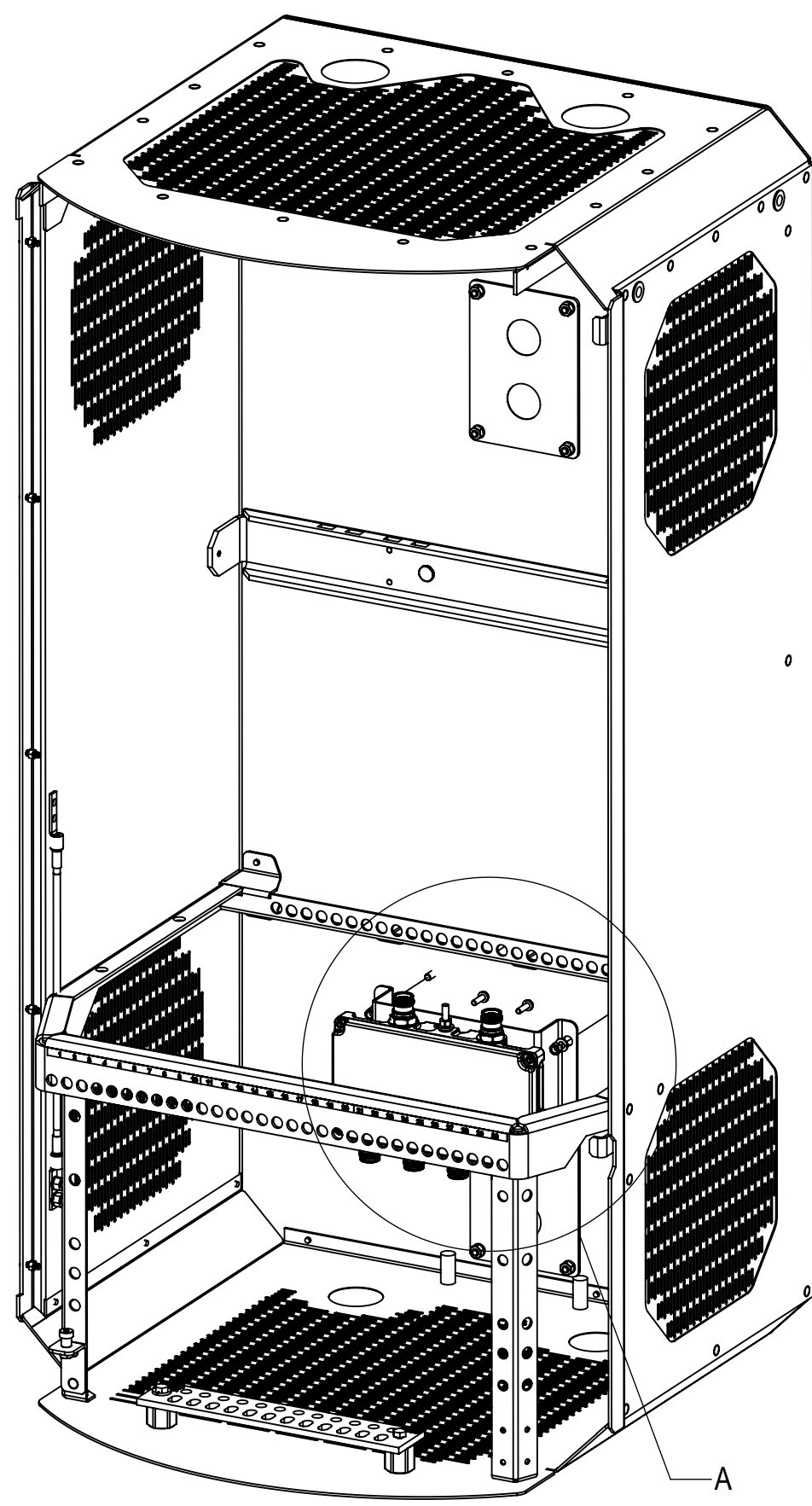

STEP 1:  
CBC1726T-4310  
 INSTALL CBC1726T-4310 TO THE EQUIPMENT AND SECURE USING  
 4 SETS OF 1/4" LOCK WASHER AND FLAT WASHER

STEP 2:  
AHFIB  
 INSTALL THE SUB-ASSEMBLIES TO THE EQUIPMENT AND SECURE USING 2  
 SETS OF M6 HEX BOLTS, LOCK WASHERS AND FLAT WASHERS AS SHOWN  
 ON SHEET 5

STEP 3:  
CBC1726T-4310 & POD-8 & APAM  
 INSTALL THE SUB-ASSEMBLIES TO THE EQUIPMENT AND SECURE USING 4  
 SETS OF M6 HEX BOLTS, LOCK WASHERS AND FLAT WASHERS AS SHOWN  
 ON SHEET 5

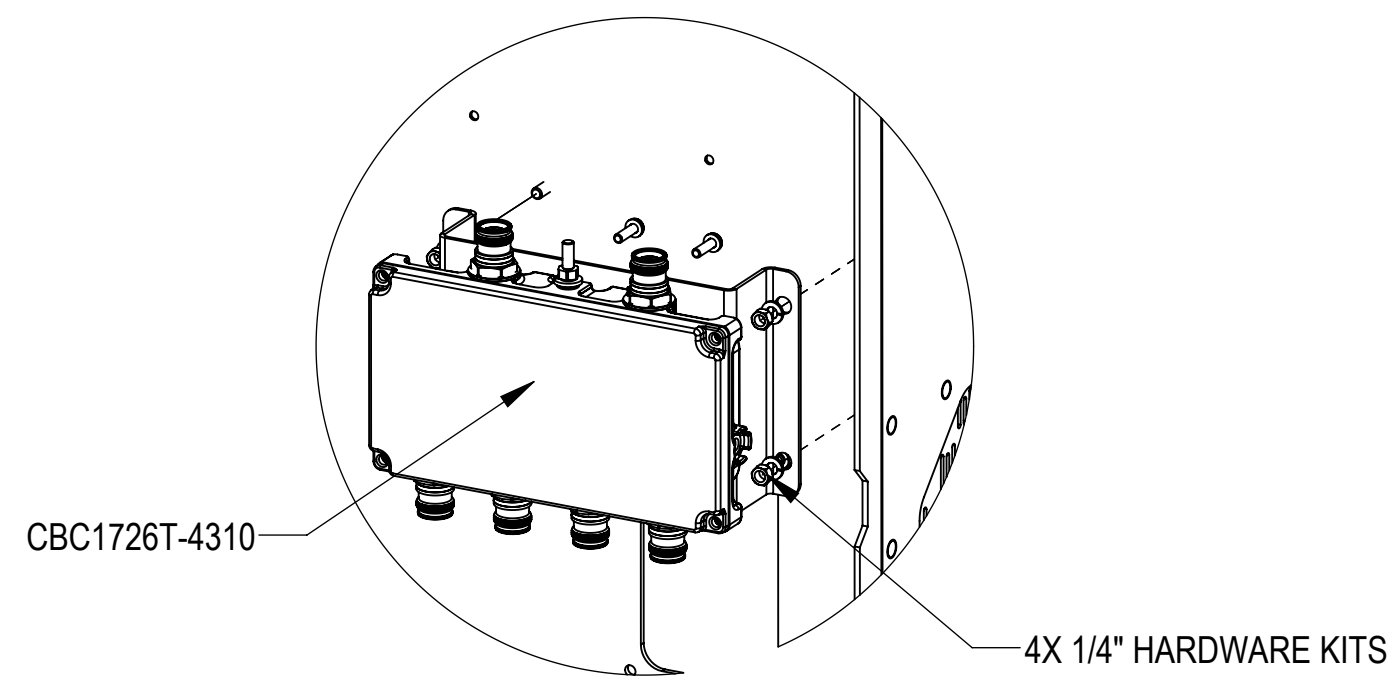

DETAIL A  
 SCALE 1 : 4

COMMSCOPE, INC. OF NORTH CAROLINA				
TITLE				
860661736-MV2-C07-INSTALL				
SIZE	SCALE	DOCUMENT NO.		
C	2:1	860661736-MV2-C07-INSTALL		
		DRAWING		
		VERSION	STATUS	REVISION
		00	RE	A
				SHEET
				6 OF 7

4

3

2

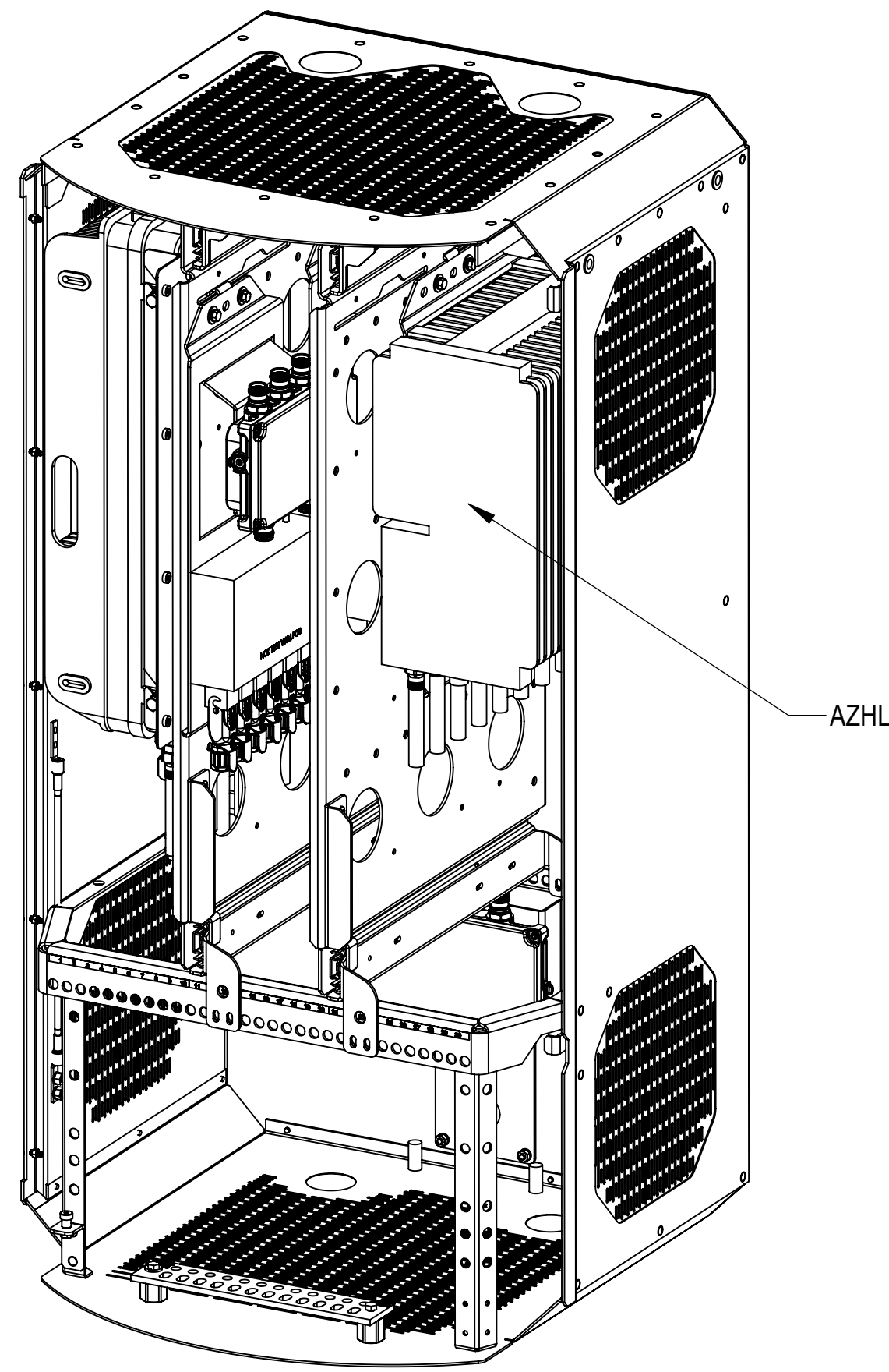

1

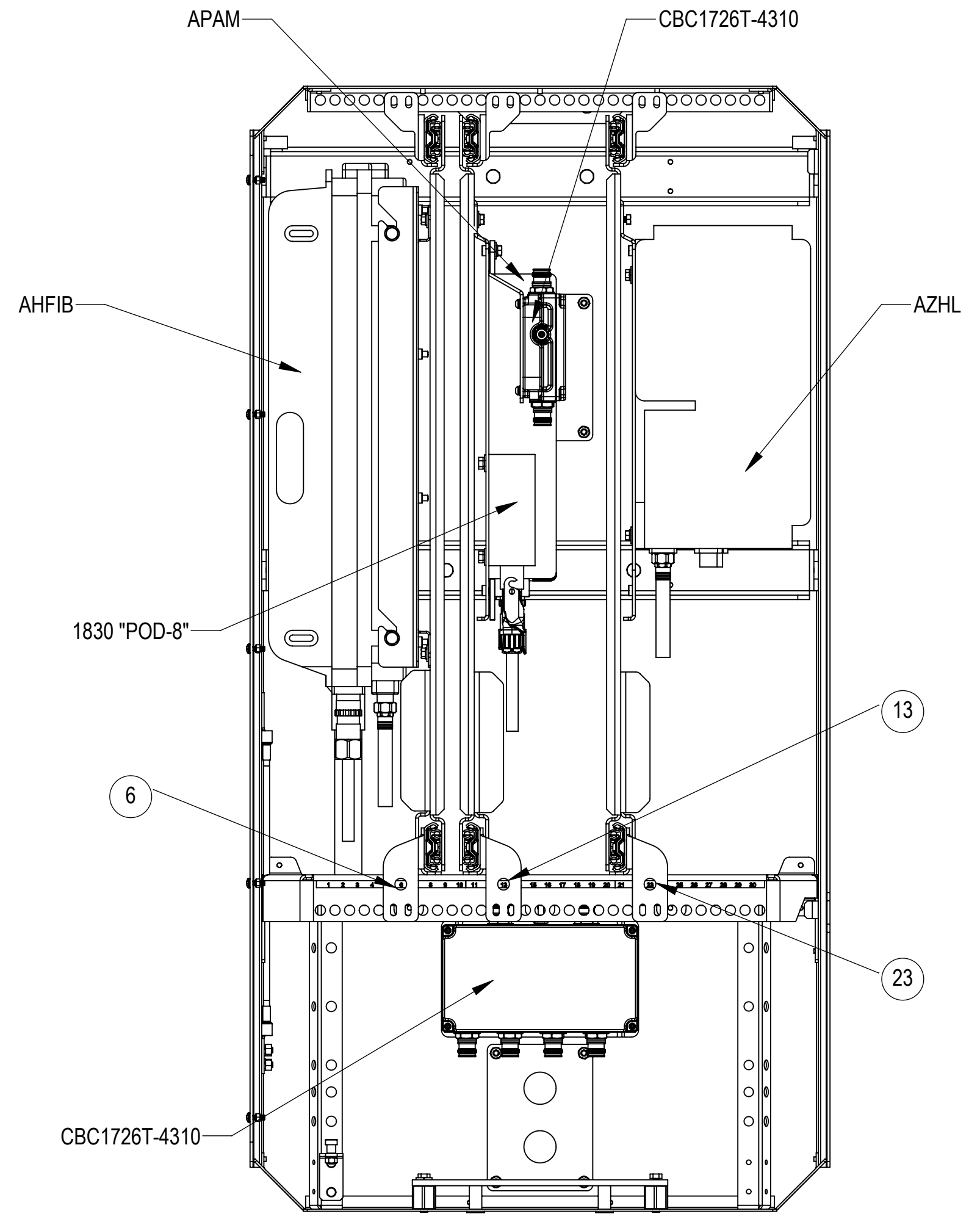

STEP 4:  
AZHL  
 INSTALL THE SUB-ASSEMBLIES TO THE EQUIPMENT AND SECURE USING 2 SETS OF M6 HEX BOLTS, LOCK WASHERS AND FLAT WASHERS AS SHOWN ON SHEET 5



**FINISHED PRODUCT**

COMMSCOPE, INC. OF NORTH CAROLINA				
TITLE 860661736-MV2-C07-INSTALL				
SIZE <b>C</b>	SCALE <b>2:1</b>	DOCUMENT NO. 860661736-MV2-C07-INSTALL		
 		DRAWING		SHEET
		VERSION 00	STATUS RE	REVISION A