

SYSTIMAX 360™ MP-4U Termination Panel with Fiber Management Bar Instructions

General

The **SYSTIMAX 360™** MP-4U panel is designed to accept sixteen **360 InstaPATCH® Plus** modules and a variety of available MPO adapter and blank panels. The panel mounts in a standard 19-inch (483mm) equipment rack or in a 23-inch (584mm) rack and ETSI rack using the 600-23BRKT accessory kit. This product is intended for indoor use or can be used outdoors in a suitable protective enclosure.

Ordering information is listed below:

Material ID	Part No.	Description
760193862	360MP-4U	MP-4U termination panel with fiber management bar



SYSTIMAX 360™ MP-4U Panel

How to Contact Us

- To find out more about **CommScope®** products, visit us on the web at <http://www.commscope.com/>
- For technical assistance:
 - Within the United States, contact your local account representative or technical support at 1-800-344-0223. Outside the United States, contact your local account representative or **PartnerPRO™** Network Partner.
 - Within the United States, report any missing/damaged parts or any other issues to **CommScope** Customer Claims at 1-866-539-2795 or email to claims@commscope.com. Outside the United States, contact your local account representative or **PartnerPRO** Network Partner.

Tools Required

- Phillips head screwdriver
- Flat-blade screwdriver

Optional Tools

- 760053199 Fiber optic connector cleaning and inspection kit
- 760053207 Fiber optic connector cleaning and inspection consumables

Related Components for 360 MP-4U Panels

Ordering information for available accessories is listed below.

Material ID	Part No.	Description
760032102	MODG2-BLANK	G2 modular blank panel bezel (package of 4)
760032110	MODG2-MGS	G2 modular MGS bezel (package of 4)
760039875	G2-SRF	Liquid-tight cable fitting kit for small-diameter cables
760039883	G2-23BRKT	Frame mounting bracket kit for 23" frames and ETSI frames
760107482	DP360-BLANK	360 InstaPATCH blank panel (pkg of 4)
760107490	DP360-2MPO	360 InstaPATCH 2 MPO adapter panel
760107508	DP360-4MPO	360 InstaPATCH 4 MPO adapter panel
760107516	DP360-6MPO	360 InstaPATCH 6 MPO adapter panel
760107524	DP360-8MPO	360 InstaPATCH 8 MPO adapter panel
760101410	360G2-4U-FLK	360G2 4U trough flip label kit
760058677	RMB-6-1/2	InstaPATCH Plus attachment bracket, rack mounted, six 1/2" fittings
760058685	RMB-6-3/8	InstaPATCH Plus attachment bracket, rack mounted, six 3/8" fittings
760110098	CMB-360MP-1U	Cabinet mount bracket spacer kit (one kit per bracket set)
Various	—	RMB-type rack mounted cable bracket kit

Contact your **SYSTIMAX** sales representative for more information on a wide variety of modules, panels, trunk cables and accessories that are compatible with these panels.

Parts List

Verify parts against the parts list below:

Quantity	Description
1	Panel
2	Fiber management bars with mounting brackets
16	Fiber routing clips
2	Hardware bezel cover
6	Oblong fiber rings
1	Front door
1	Flip label holder
3	Label hangers
12	#12-24 x 1/2 screws for 19-inch and 23-inch rack/cabinet mounting
12	M6 X 12 screws for ETSI rack/cabinet mounting
1	R2300 fastener kit (hook-and-loop straps)
1	Instruction sheet

Precautions

- **360 InstaPATCH Plus** modules contain fiber optic cable and passive optical components. When removed from protective packing, they should be handled carefully and installed in appropriate racks for mechanical support and protection.
- **360 InstaPATCH Plus** modules require virtually no maintenance to maintain their performance. They contain no user-serviceable components, and any damage to the anti-tamper label or removal of top cover or front adapter mounting panel will void the warranty.
- Fiber optic trunk cable and jumper performance is sensitive to bending, pulling, and crushing. Minimum bend radius must be maintained during installation per the manufacturer's specification. Appropriate pulling grips must be used during installation, and pulling forces shall not exceed manufacturer's recommendations. Use caution to avoid kinking trunk cables.
- Care should be taken not to compromise the stability of the rack by installation of this equipment.
- To be installed in restricted access areas only.

CAUTIONS

- Isopropyl alcohol is flammable, and can cause eye irritation on contact. If eye contact occurs, flush with water for at least 15 minutes. In case of ingestion, consult a physician. Use only in well ventilated areas.
- Disconnected optical components may emit invisible optical radiation that can damage your eyes. Never look directly into an optical component that may have a laser coupled to it. Serious and permanent retinal damage is possible. If accidental exposure to laser radiation is suspected, consult a physician for an eye examination.
- Wearing safety glasses during installation of this panel is recommended. Although standard safety glasses provide no protection from potential optical radiation, they offer protection from accidental airborne hardware and cleaning solvents.

Connector Cleaning

- **360 InstaPATCH Plus** modules are pre-terminated, with either protective dust caps (SC) or integral hinged shutters (LC) installed on all adapters. Connectors internal to the adapters are clean when purchased.
- Clean trunk cable and jumper connectors per manufacturer's recommendations prior to connection to the panel.
- If trunk cables or jumpers are removed, replace provided dust caps (SC) on the adapters to protect the internal connectors.

Step 1 – Mount Panel to Equipment Rack and Install Loose Parts

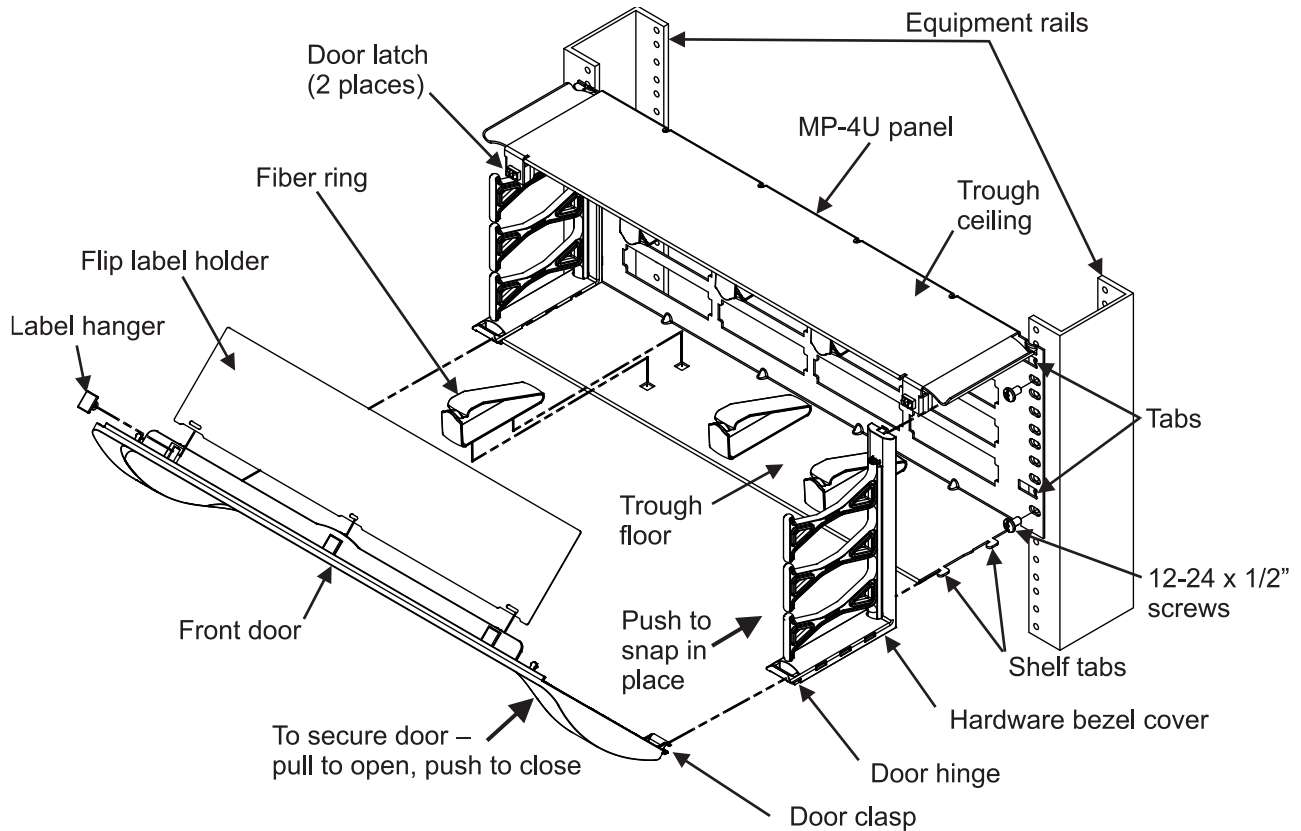

1. Align tabs on panel (two per side) with holes on front of equipment rails.

Note: If tabs do not insert into holes in equipment rails without interference, DO NOT FORCE as damage to shelf will result. In this case, tabs must be bent back or trimmed off to eliminate interference. This situation is usually caused by equipment racks/cabinets being improperly assembled. Great care should be taken when assembling racks/cabinets to assure that the rails are properly aligned. Use of an alignment tool is recommended.

2. Mount panel to equipment rails using the four 12-24 x 1/2-inch screws provided. If installing panel on other than a 19-inch rack, follow instructions below.
 - For 23-inch rack – From the 600-23BRKT accessory kit (available separately), install two conversion brackets to the panel mounting flanges using the four #10-32 x 3/8-inch conversion screws included in the accessory kit. One conversion bracket and two screws per side. Mount the shelf to the equipment rails using the four #12-24 x 3/8-inch screws provided with panel.
 - For ETSI rack – From the 600-23BRKT accessory kit (available separately), install one conversion bracket to either of the panel mounting flanges using two of the four #10-32 x 3/8-inch conversion screws included in the accessory kit. The shelf will not be centered when mounted in the rack. Mount the shelf to the rack using the four M6 x 12mm screws provided with panel.
3. Install hardware bezel covers by fastening upper latch of bezel cover to upper lance of panel.
4. Insert two tabs on bottom of panel into openings on bottom of bezel cover.
5. Push bezel cover towards mounting rail until bezel overrides lock on panel and snaps into place.
6. Install oblong fiber rings to trough floor and ceiling.

Step 2 – Install, Open, or Remove Front Door

1. Position door at 45° and align door clasps on lower corners of door to hinges on hardware bezel cover and push in on each corner to engage the two components.
2. Swing door up and down freely to verify proper installation.
3. Swing door up to the closed position and push in on upper corners to engage latches and secure door.
4. To open front door, pull on upper corners of door to disengage latches, then swing open.
5. Remove protective film from inside and outside of door.
6. To remove front door, open door and position it at 45°. Slide door to either side to disengage clasp from hinge.

Note: Take special care when removing door to prevent scratches, damage, or loss.

7. To close door, push on upper corners of door, engaging tab to door latch.

Step 3 – Install Modules and Panels

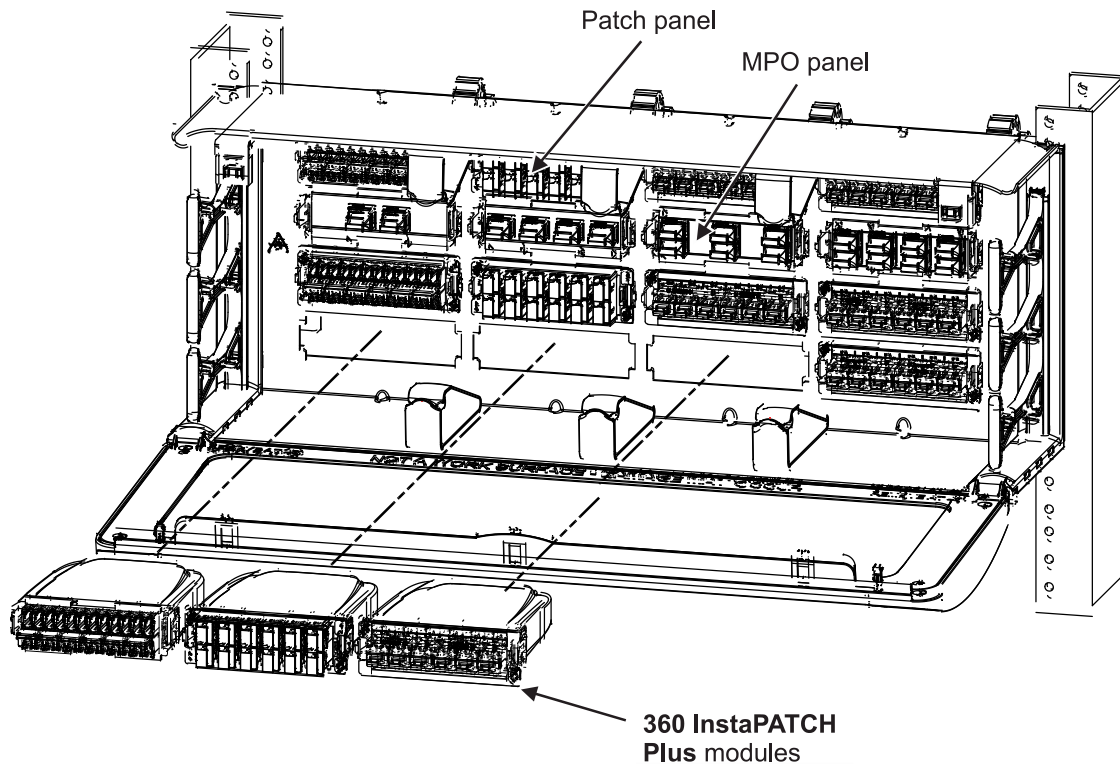

1. Starting at lower left position, remove blank cutout cover and plug module or panel into bulkhead cutout.

Step 4 – Mount Fiber Management System and Route Trunk Cables

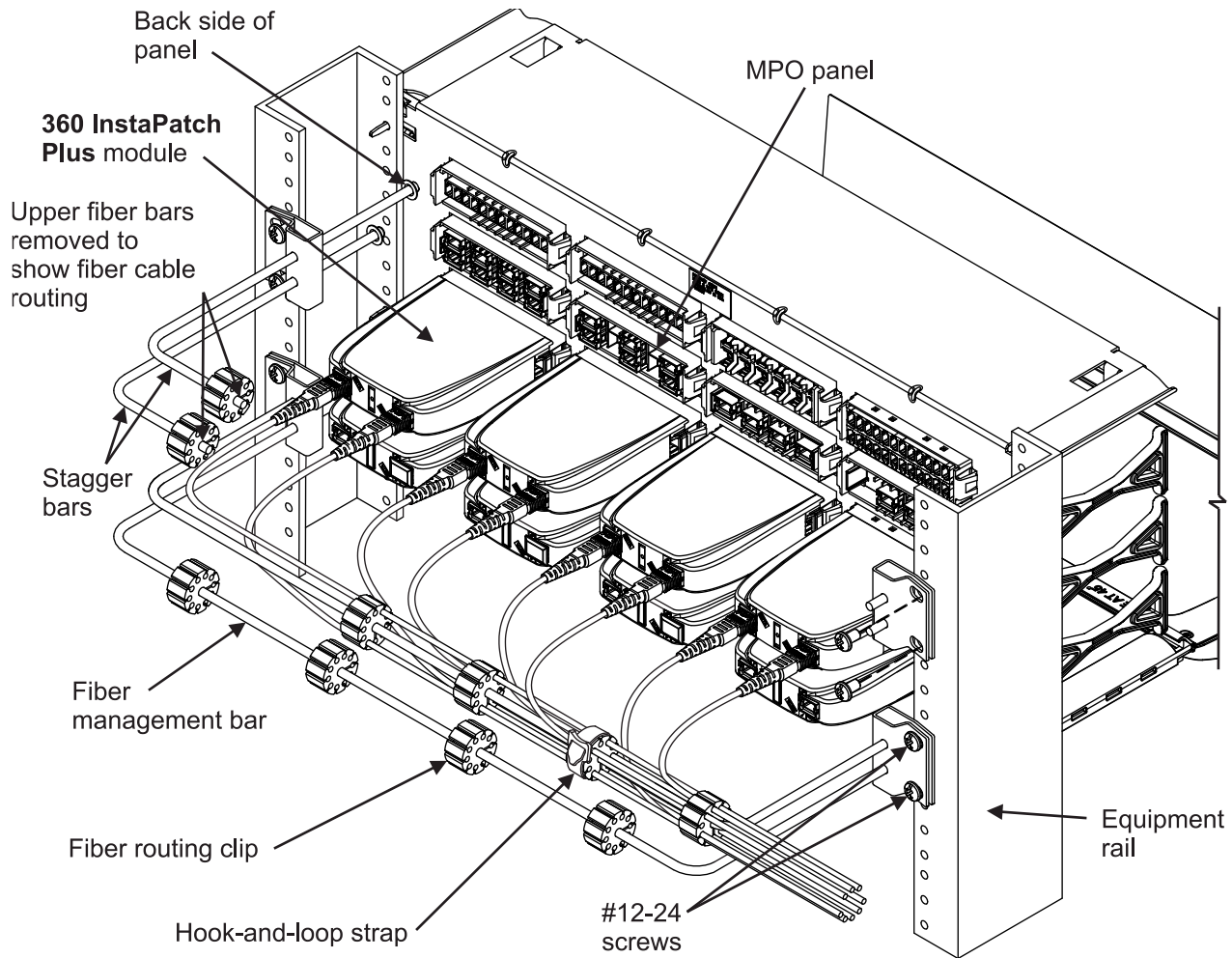

Note: To install the fiber management bar in a cabinet or rack with a single sided rail (“L” shaped as opposed to “[” shaped), the fiber management bar spacer kit (760110098) is included and must be used. See figure on next page.

1. Determine the fiber management bar desired mounting location. Bar retention bracket should be centered with either upper set of panel openings or lower set of panel openings.
2. Loosely secure bar retention brackets to equipment rails using the four provided 12-24 screws. Do not fully tighten screws.
3. Slide one bar into brackets until it contacts the back side of the panel. Stagger the second bar.
4. Tighten the four 12-24 screws fully to secure bar in position.
5. Place four fiber routing clips over each fiber management bar approximately where shown above by opening slit in clip and inserting it over bar.
6. Mate MPO connector(s) on module with those on trunk cable or ruggedized fan out.
7. Spread open a slot position provided on fiber routing clip and secure fiber cable inside.
8. Repeat until all cables are secured and adjust position of clips as required for a smooth routing.
9. Wrap hook-and-loop straps around fiber clips to secure cables.

Note: It is recommended to begin routing fiber cables from the module nearest the side of planned fiber exit and work toward module furthest away.

Note: To secure InstaPATCH or ReadyPATCH cables, use the separately ordered rack mounted cable bracket (RMB) kit and follow the instructions included in the kit as shown below.

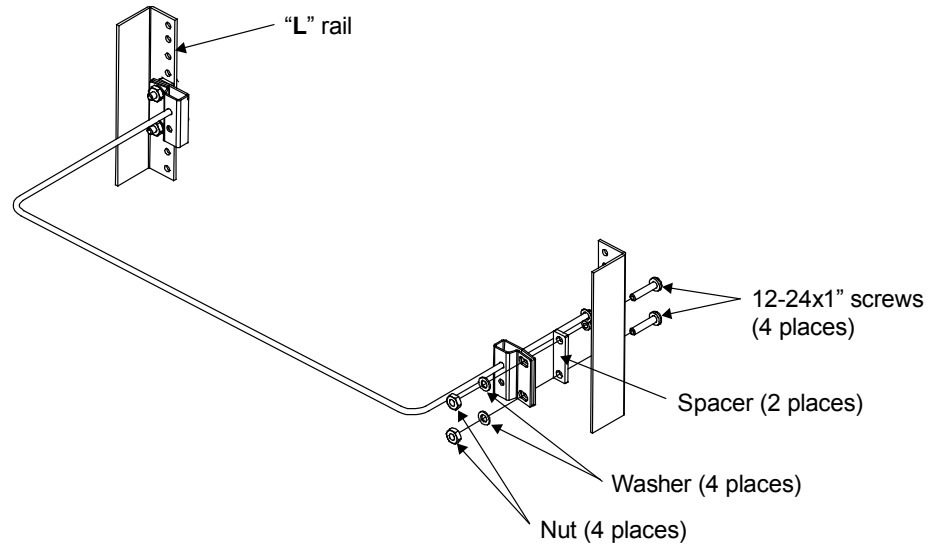

Step 5 – Install Fiber Designation Label

- To print a designation label, go to <http://www.commscope.com/Resources/Labeling-Templates> and scroll down to **360G2 Panels and Shelves** and select the appropriate label template.
- Open trough door to 90°, orient the three provided label hangers as shown, and insert them into openings in rib on trough door as shown.
- Orient label holder perpendicular to label hangers with slots aligned with hangers. Insert edge of label holder into hangers so that slots slide over the hangers. The label holder should pivot on the hangers freely.
- Apply labels on surface of flip label holder facing door to be seen when door is closed.

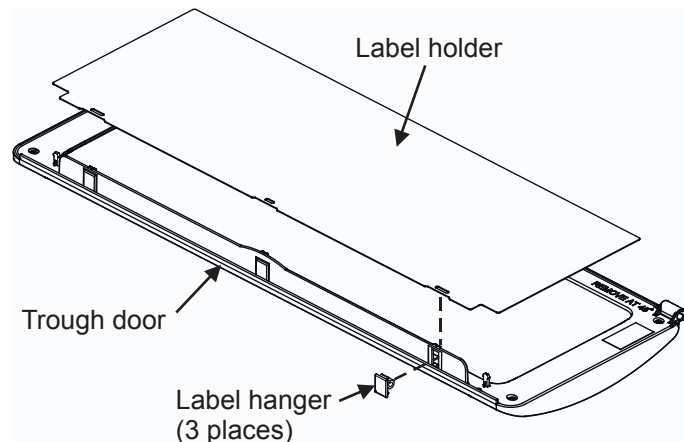

Step 6 – To Remove Bezel Cover

- Using a flat blade screwdriver, depress upper latch on panel to free bezel cover.
- Pull bezel towards front to override tab locks on bottom of panel.
- Release bezel from tabs on floor of panel.