

| REV | MCO      | DWN | DATE      |
|-----|----------|-----|-----------|
| D   | 20169114 | GNM | 04-MAY-05 |
| E   | 20237120 | AED | 08-APR-08 |

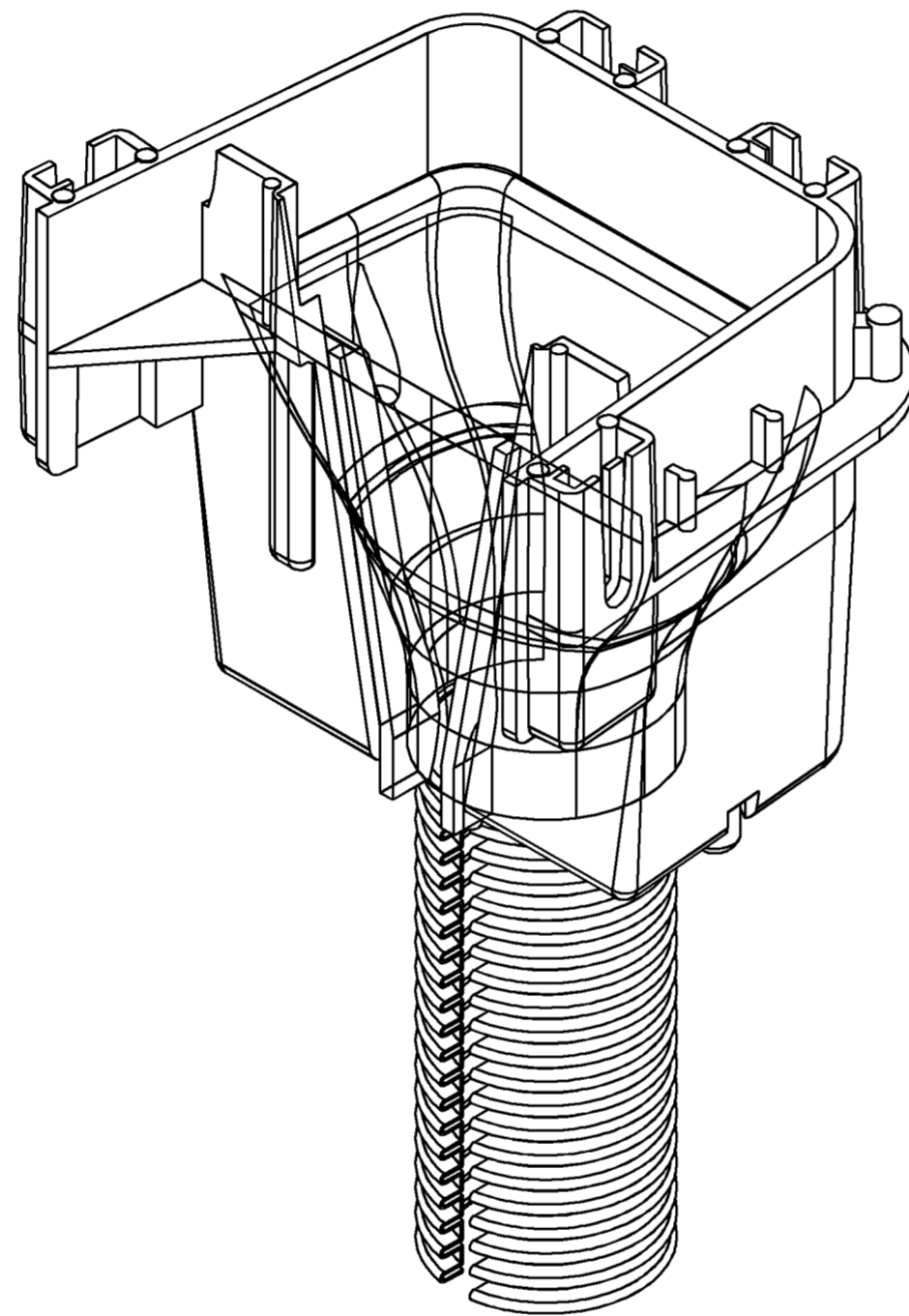

| CATALOG NO.    | TUBE LENGHT | COLOR  | SLOTTED TUBE | RETAINING RINGS |
|----------------|-------------|--------|--------------|-----------------|
| FGS-ASRI-5F    | 5 FT        | YELLOW | YES          | 3               |
| FGSO-ASRI-5F   | 5 FT        | ORANGE | YES          | 3               |
| FGS-ASRI-10F   | 10 FT       | YELLOW | YES          | 5               |
| FGSO-ASRI-10F  | 10 FT       | ORANGE | YES          | 5               |
| FGS-ASRI-15F   | 15 FT       | YELLOW | YES          | 7               |
| FGSO-ASRI-15F  | 15 FT       | ORANGE | YES          | 7               |
| FGS-ASRI-5F/NS | 5 FT        | YELLOW | NO           | 3               |
| FGSB-ASRI-5F   | 5 FT        | BLACK  | YES          | 3               |
| FGSB-ASRI-10F  | 10 FT       | BLACK  | YES          | 5               |
| FGSB-ASRI-15F  | 15 FT       | BLACK  | YES          | 7               |

NOTES:

1. ALL NON-METALIC COMPONENTS OF THIS ASSEMBLY ARE SELF EXTINGUISHING WITH UL 94 RATING OF V-0.
2. IT IS GOING TO DEPEND ON THE TUBE LENGTH.

| INCLUDED HARDWARE |                   |
|-------------------|-------------------|
| QTY               | DESCRIPTION       |
| -                 | RETAINING RING    |
| 1                 | HOSE END CLAMP    |
| 2                 | SCREW 6-32 X .375 |
| 2                 | WASHER            |
| 2                 | NUT 6-32          |

2



|   |  |   |                                |
|---|--|---|--------------------------------|
| INFORMATION ON THIS DOCUMENT IS PROPRIETARY TO ADC AND SHALL NOT BE USED, COPIED, REPRODUCED OR DISCLOSED IN WHOLE OR IN PART WITHOUT WRITTEN CONSENT OF ADC. |  | TITLE<br>FIBERGUIDES ROUND TO SQUARE INST DRW |                                |
| ALL DIMS AND TOLERANCES ARE INCHES UNLESS OTHERWISE SPECIFIED   | .XX:±.02<br>.XXX:±.010<br>ANGULAR:±N/A | C<br>SIZE                                     | DRAWING NUMBER<br>4-29000-2538 |
| DO NOT SCALE DRAWING  |  | ENGR: R HENNEBERGER<br>DWN: D CARPENTER       | E<br>REV                       |
|   |  | SHT. 1  | OF 1                           |

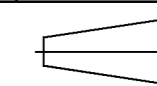
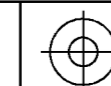

**DIMENSIONS IN INCHES  
THIRD ANGLE PROJECTION**