

4

3

2

1

- 1.0 GENERAL NOTES
 - 1.1 ALL METRIC DIMENSIONS ARE IN BRACKETS [X.X]
 - 1.2 FEATURES CRITICAL TO QUALITY ARE INDICATED IN ROUNDED BOX (X.X)
 - 1.3 3D DIGITAL FILES ARE FOR REFERENCE. IN CASE OF CONFLICT FOLLOW PDF DRAWING
- 2.0 DESIGN NOTES
- 3.0 MANUFACTURING/SPECIAL REQUIREMENTS
 - 3.1 BREAK SHARP EDGES AND DEBURR PART FOR SAFE HANDLING
 - 3.2 GALVANIZE PER ASTM A123
 - 3.3 MARK WITH PART NUMBER, REVISION, AND VENDOR ID WITH ETCH, STAMP OR LABEL. CHARACTERS TO BE 0.12" TO 0.24" HIGH AND LEGIBLE TO THE UNAIDED EYE.
- 4.0 TEST
- 5.0 PACKAGING
 - 5.1 PACKAGING SHALL MEET COMMSCOPE REQUIREMENTS PER DOCUMENT IS-PL-3005

REVISIONS			
REV.	DESCRIPTION	DATE	APPROVED
A	INITIAL RELEASE	JL1183 18OCT23	XK1001 4079678CMO
B	UPDATED NOTES AND REMOVED BARE LEVEL	LL1090 28AUG24	BA1025 40203400CMO

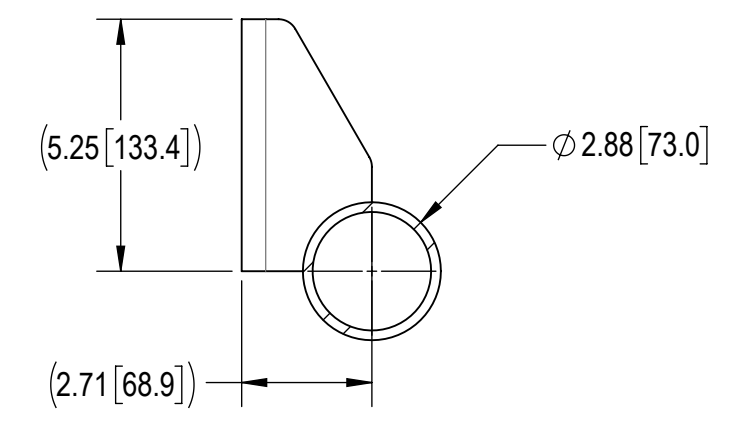
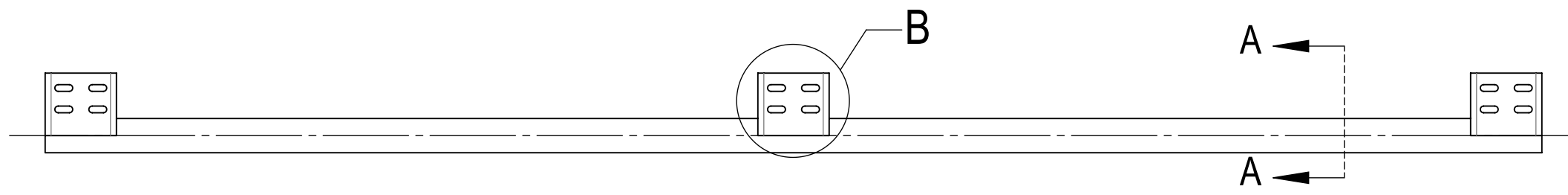
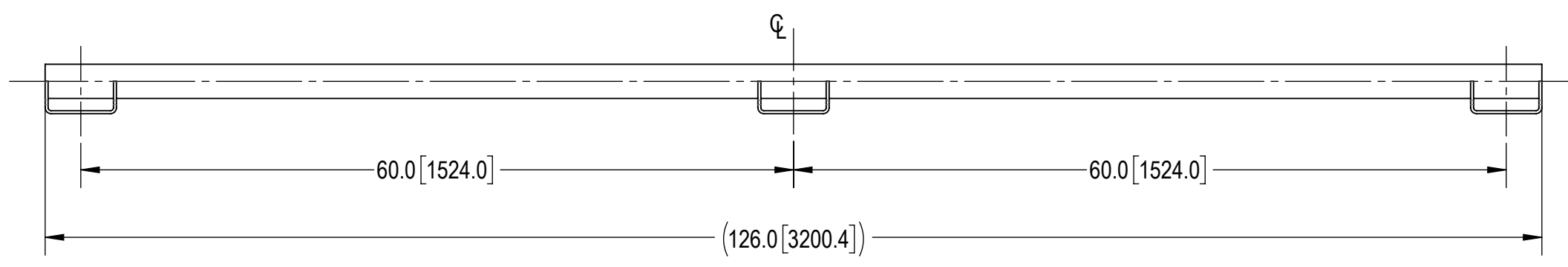

VIEW A-A
SCALE 1 : 4

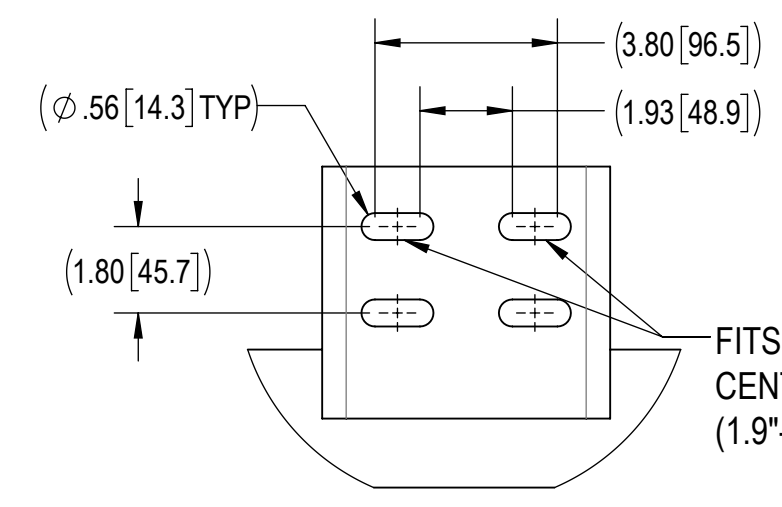

DETAIL B
SCALE 1 : 4

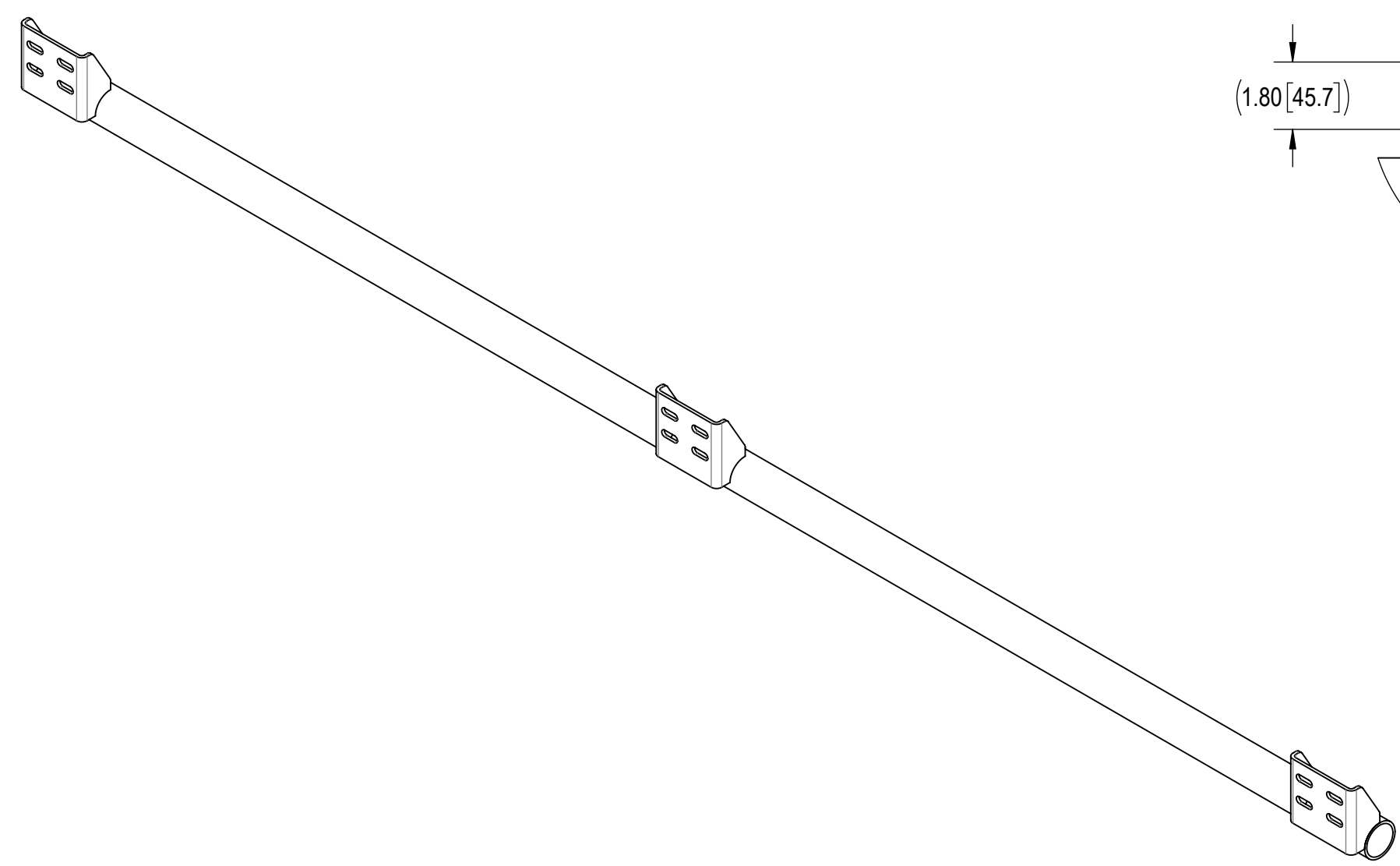

DENSITY	70.48	lbs/in ³
MASS	70.48	lbs
VOLUME	247.87	in ³
SURFACE AREA	2415.91	in ²
HEIGHT	6.69"	
LENGTH	126.0"	
WIDTH	4.15"	

COMMSCOPE, INC. OF NORTH CAROLINA

TOLERANCES		SAP MATERIAL MASTER							
1 PLACE .X[X] ± 0.2[6.3]	3 PLACE .XXX[X] ± 0.060[1.5]	SFG-FP-10.5-3-60							
2 PLACE .XX[X] ± 0.12[3.0]	ANGLES ± 2°								
FINISH GALV A123		MATERIAL A1018, A500							
UNLESS OTHERWISE SPECIFIED DIMENSIONS ARE IN INCHES INTERPRET PER ANSI Y 14.5M-1994	NAME	DATE	FACE-PIPE, 2.88"X10.5', 3-POS, 60"						
	CE JL1183	18OCT23							
	RW YMENG	08/28/2024							
	AD BA1025	08/28/2024							
	RE YMENG	08/28/2024							
ECN 40203400CMO	SCALE 1:12		DOCUMENT NO. SFG-FP-10.5-3-60						
SIZE	Auth Group	INSL	MODEL	DRAWING			SHEET		
C			VERSION	STATUS	REVISION	VERSION	STATUS	REVISION	1 OF 1
			00	RE	A	01	RE	B	